



# DRAG CHAIN CONVEYORS

## CONTENTS

<b>2</b>	Drag Chain Conveyors
<b>4</b>	LOUISE Chain Conveyor
<b>6</b>	Conveying Geometry
<b>8</b>	Applications
<b>13</b>	Gravity Chain Tensioning
<b>14</b>	Tension Station Drive Station
<b>15</b>	Fork Link Chains
<b>16</b>	Conveying Capacity
<b>17</b>	Standard Chain Conveyor dimensions
<b>18</b>	Conversion & Refurbishments
<b>19</b>	After-Sales Service

## DRAG CHAIN CONVEYORS

LOUISE Chain Conveyors type TKF, are operating in installations worldwide to handle powdery, coarse, fine grained, abrasive and sticky bulk materials.

LOUISE Chain Conveyors are designed to suit the properties of the bulk material, the operating hours and the conditions of the surroundings, with the appropriate chain speed and chain width being of vital importance for the service life of the conveyor.

### **LOUISE Chain Conveyors reclaim, convey, cool and distribute all kinds of bulk materials**

- **Cement industry**

Natural and FGD-gypsum, blast furnace slag, limestone, burnt lime, fine lime, clinker, marl, raw meal, cement, filter dust





Two basic ranges of applications exist:

1. **Material conveying including controlled/proportional discharge by means of equipment such as belt conveyors, rotary valves, double pendulum flap etc.**
2. **Material reclaim from silos, hoppers or filters via discharge table.**



## LOUISE CHAIN CONVEYOR

Selection of trough sections, available with single and double-strand chain depending on the application

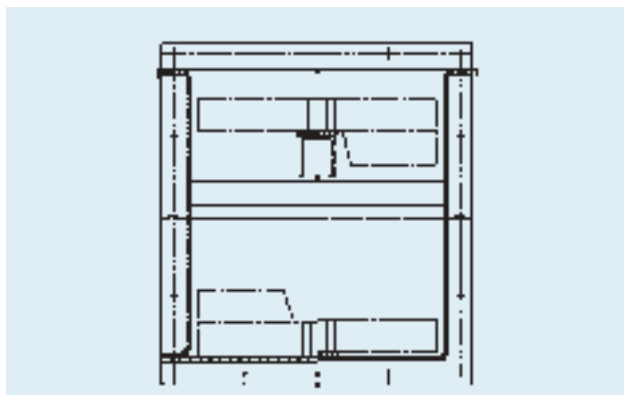
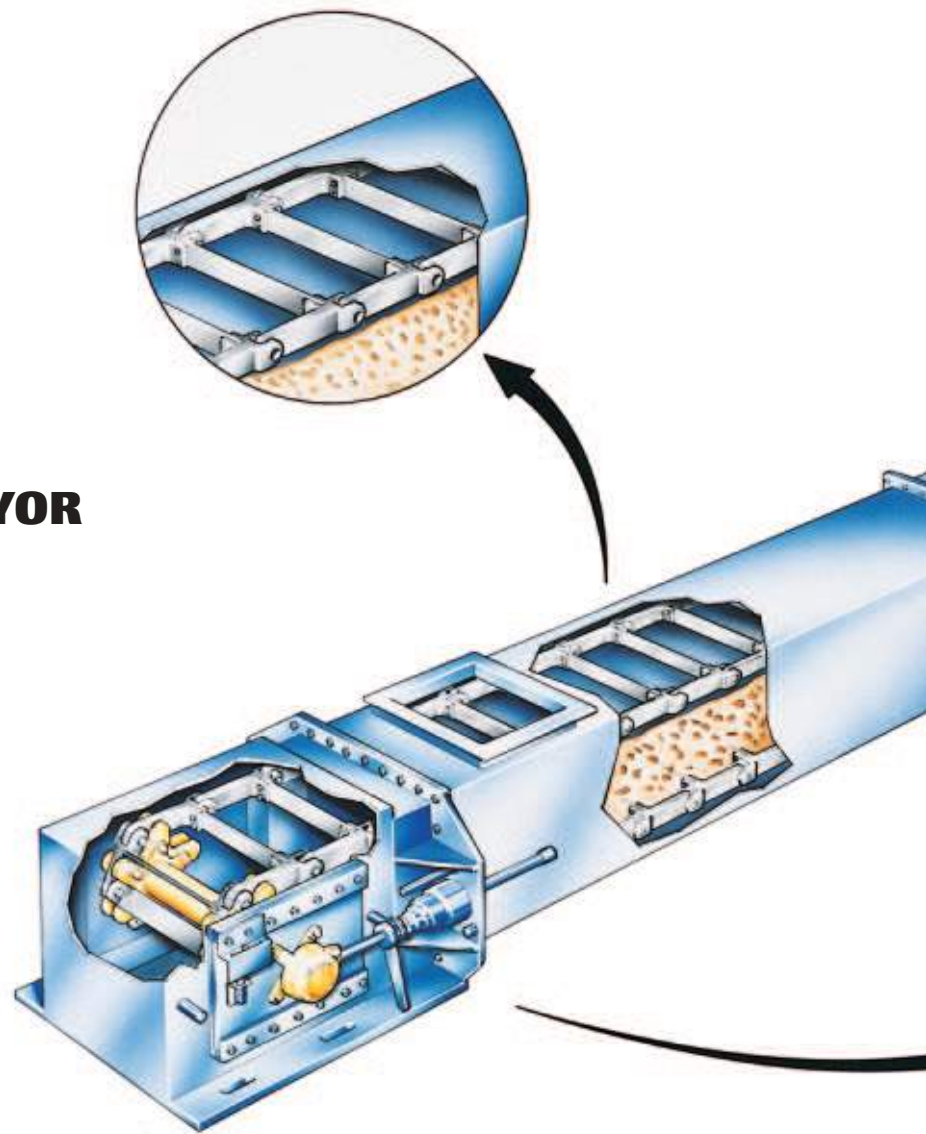

Single-strand chain with standard/oversized flights

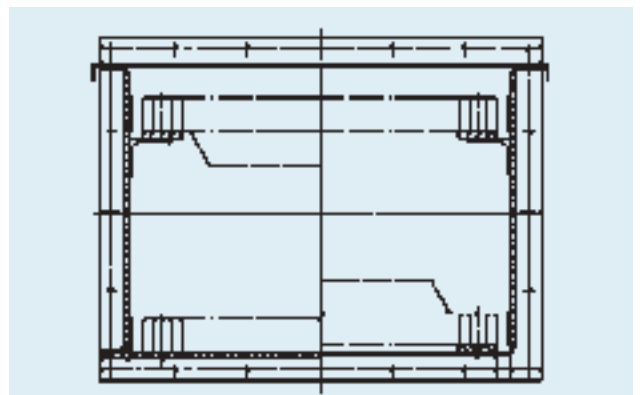

Double-strand chain with wear plates

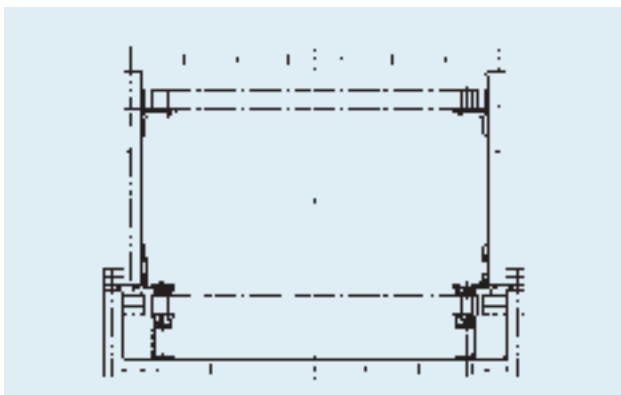
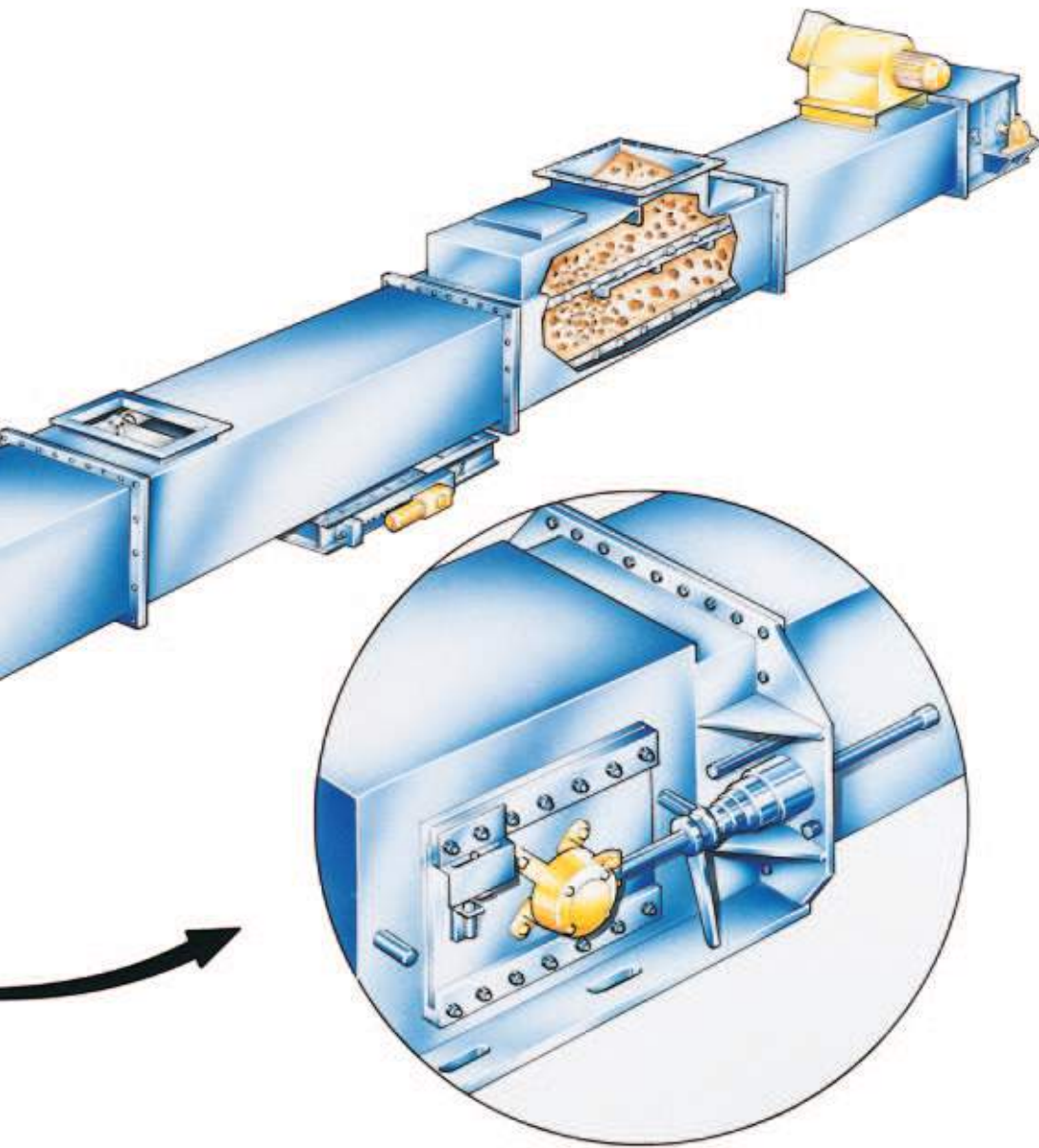

Section with material bed for clinker transport

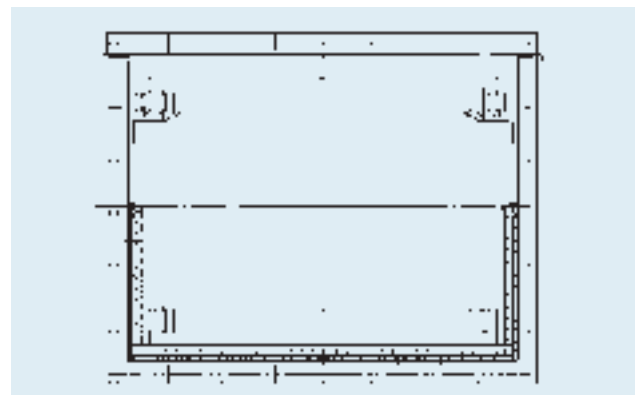

Section with cast basalt lining

# CONVEYING GEOMETRY

With their versatile geometry LOUISE Chain Conveyors fit into new or existing plant arrangements.

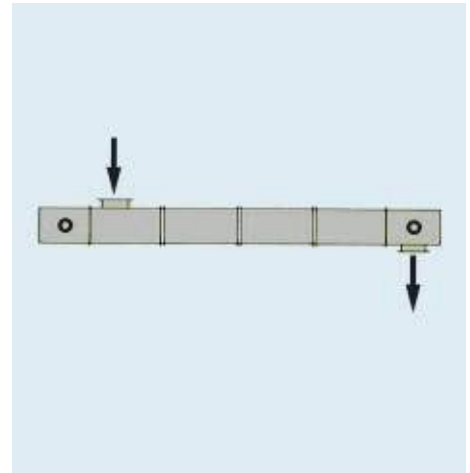

Horizontal

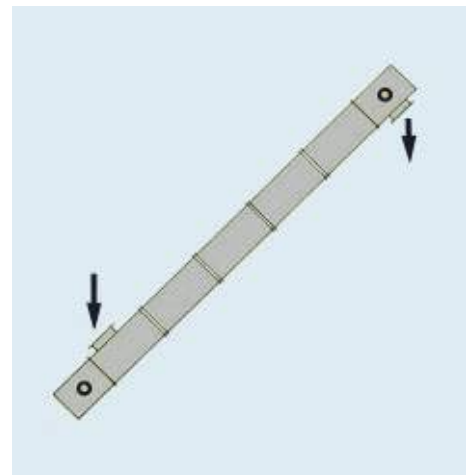

Inclined

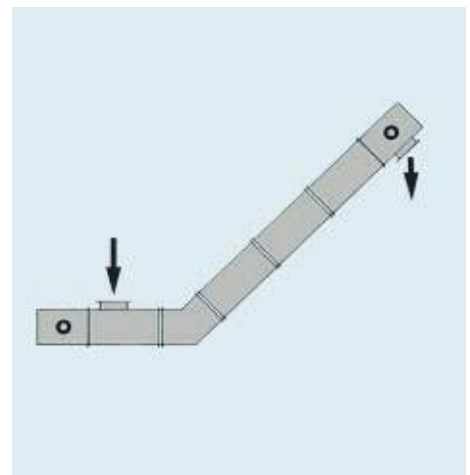

Horizontal und inclined

## CONVEYING GEOMETRY

Plant arrangements or limited space often require complex layouts for conveying equipment. **Special design**

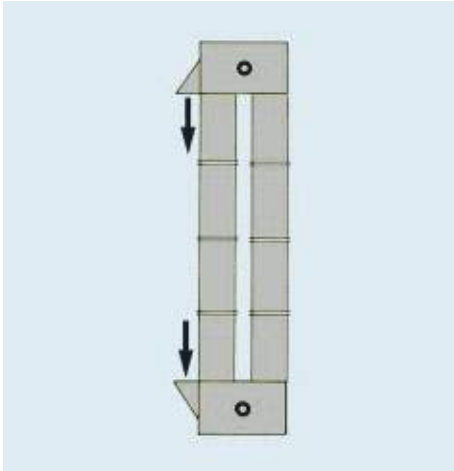

Vertical

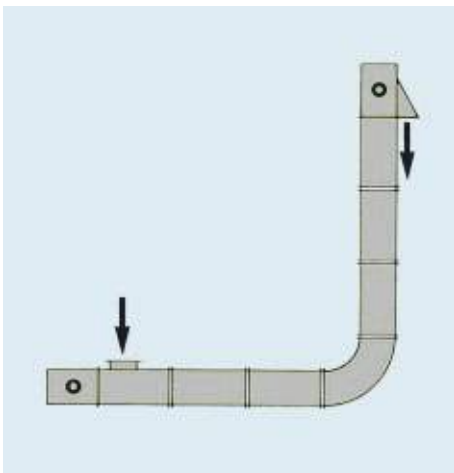

Right angle

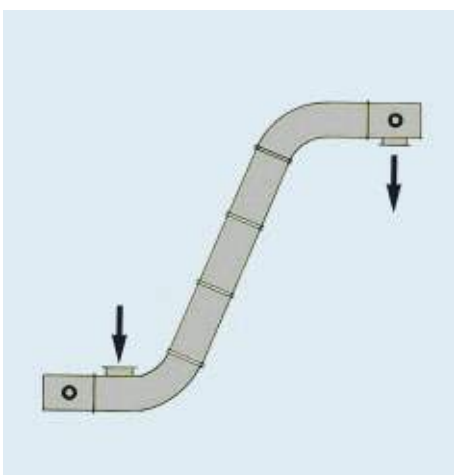

Swan neck



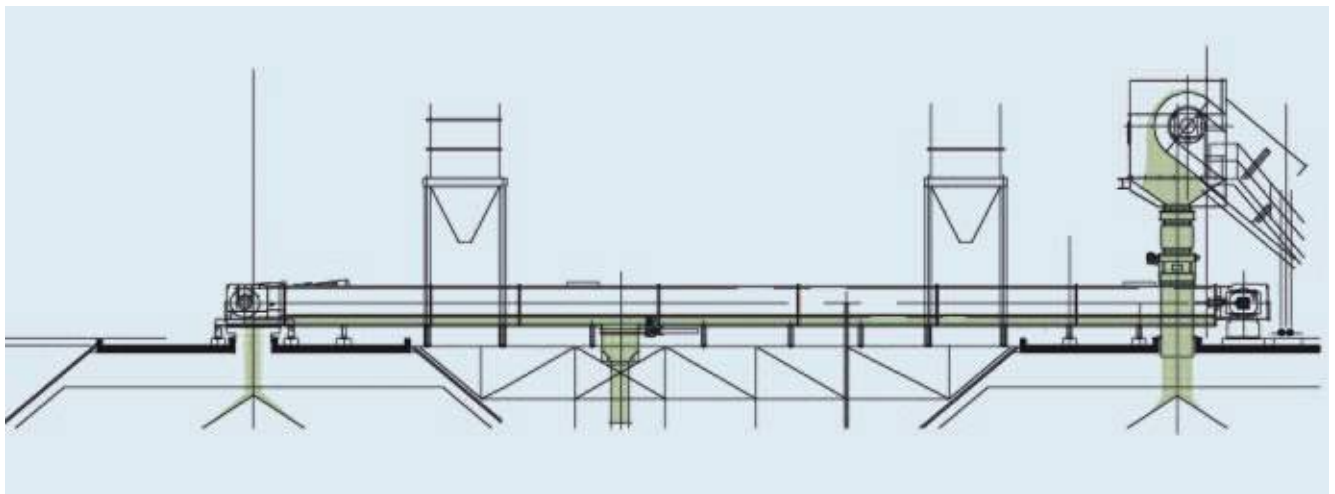

## APPLICATIONS

### Chain Conveyors for the distribution of various types of bulk materials

Chain Conveyors to convey and distribute bulk materials to different locations.

Controlled feeding of the chain conveyor is realized through one single feeding chute. The number of discharge openings varies in accordance with the plant requirements. All intermediate discharge openings are fitted with remote controlled shut-off gates allowing to choose the receiving silo from the central control room. The final discharge opening in the drive station remains open at any time.



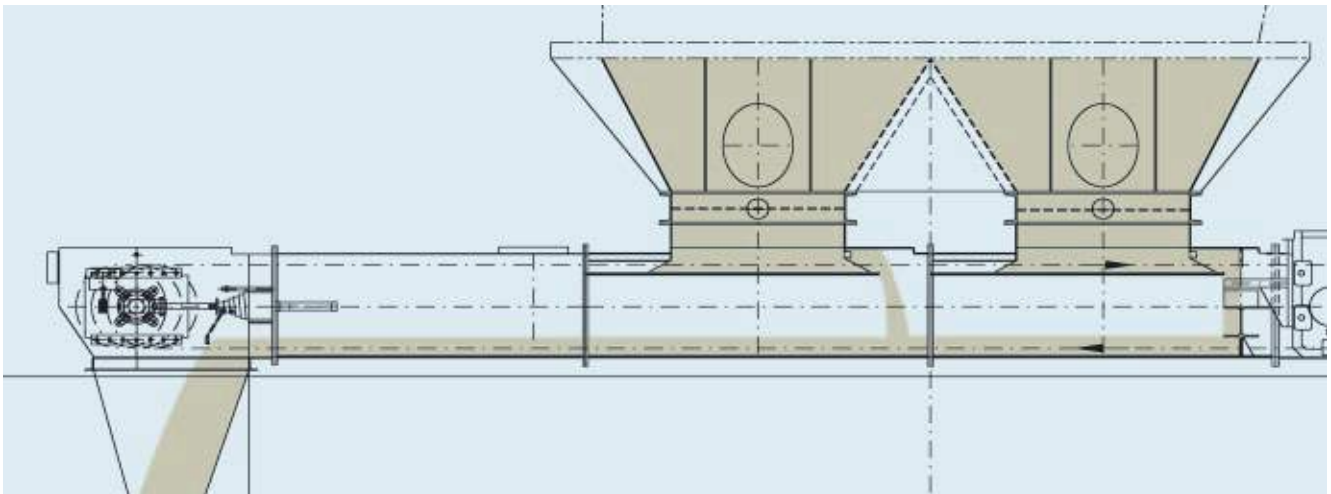

**Chain Conveyors to reclaim bulk material from various silos or hoppers**

Chain Conveyors to reclaim coal from one or several hoppers.

A double row needle gate or a motorized slide gate, open in normal operation, isolates the silo or hopper from the Chain Conveyor for maintenance purposes. During the discharge process the full load of the

bulk material is supported by a discharge table located underneath the reclaim opening on the return run. This arrangement enables the volumetric discharge at the required rate by regulating the height of the material layer either with the chain speed through the frequency converter or with a motorized or manual level control. Discharge onto subsequent equipment is realized through the discharge opening in the tension station.

## APPLICATIONS

### Submerged LOUISE Chain Conveyors for cooling and conveying of hot bottom ash in power stations

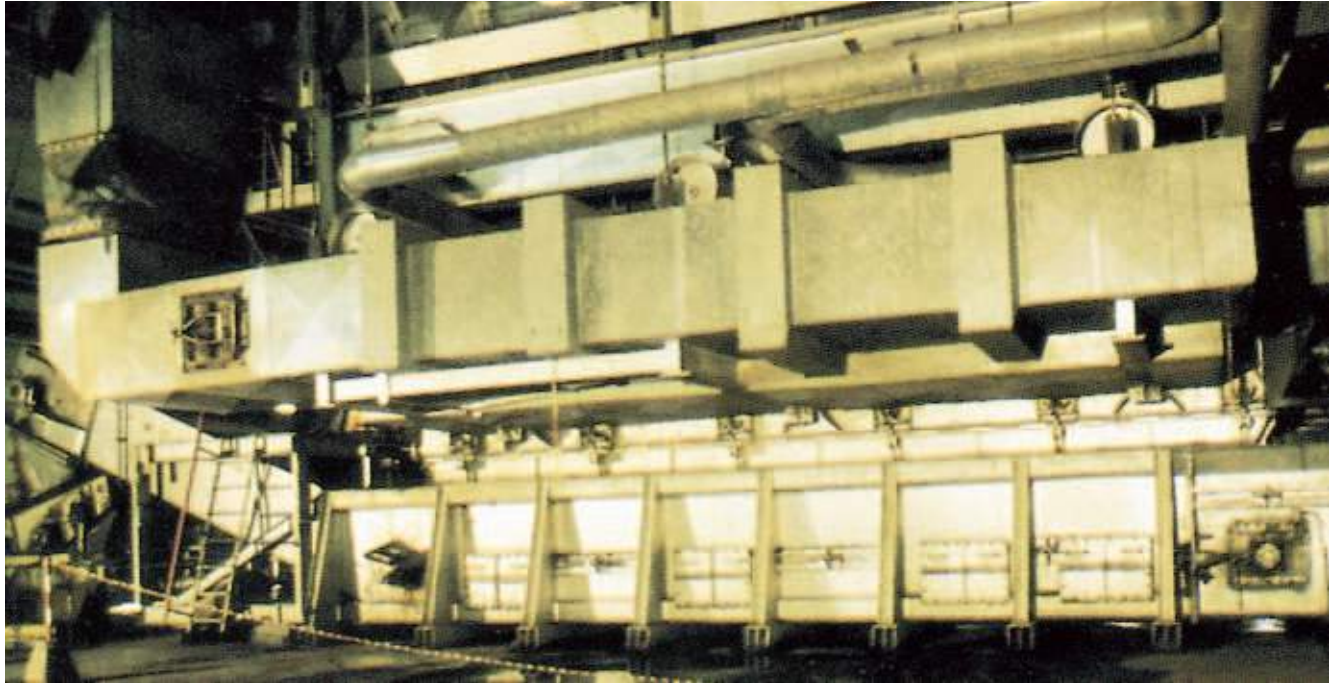

The hot bottom ash falls from the boiler directly into the submerged Chain Conveyor. Depending on the type of coal and the capacity of the boiler, the bottom ash is conveyed either with the upper or the lower chain strand.

If required the chain speed is adjustable to the actually generated ash quantity by electric control. The control unit of the chain conveyor continuously

adapts the chain speed to the ash volume, which is subject to the type of burnt coal. This feature of the LOUISE Chain Conveyor allows to avoid unnecessary high chain speed, hence keeping the wear factor at a low level.

The complete Chain Conveyor with the water bath is installed on rollers and can be removed for maintenance after closing the ash feeding gates.

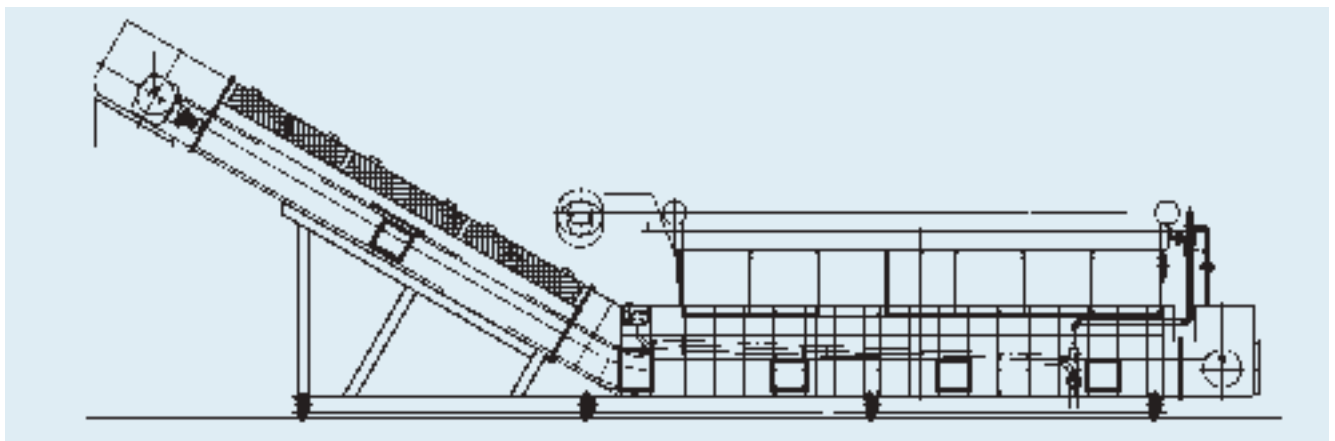

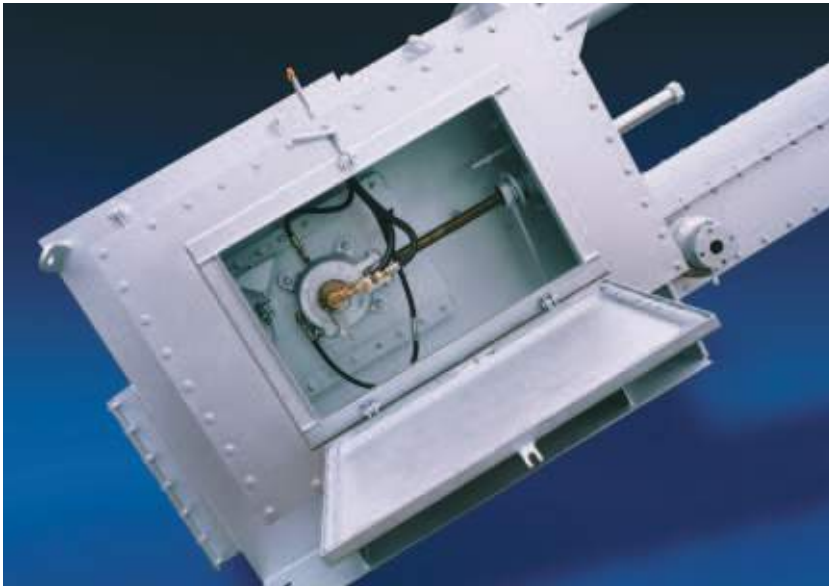

## APPLICATIONS

### **LOUISE Chain Conveyors for reclaim and dry cooling of hot bottom ash**

A particular design is the LOUISE Chain Conveyor allowing for dry cooling of hot bottom ash.

A double trough design builds the water cooling system, which protects the chain links and cools down the ash.

If non fluidised ash with a considerable angle of repose is discharged, the Chain Conveyor may remain under constant load from the material column accumulated in the boiler outlet in order to avoid loss of air during the discharge process.

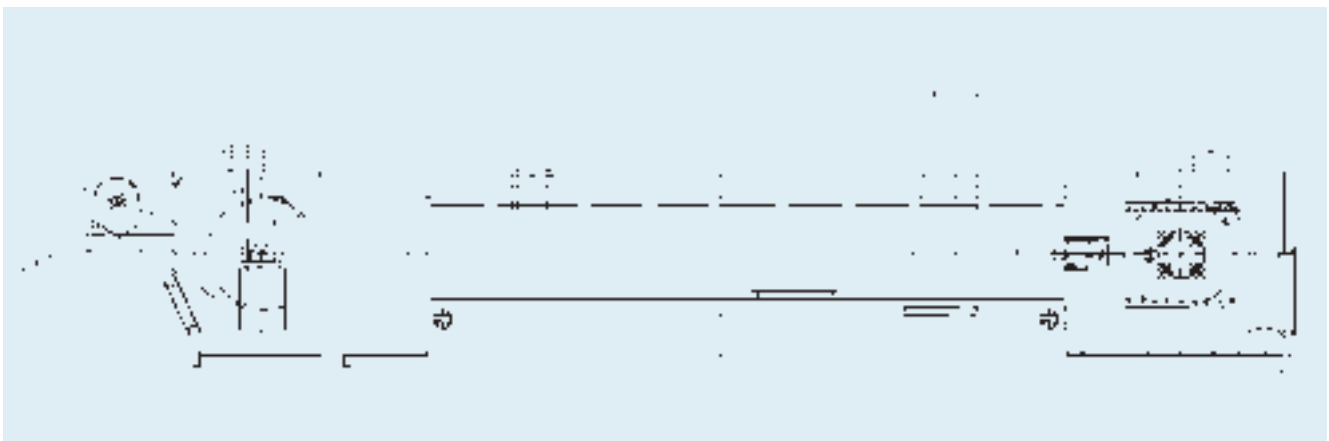

## APPLICATIONS

### Submerged LOUISE Chain Conveyors used in white cement production

#### Cooling and conveying of white cement clinker

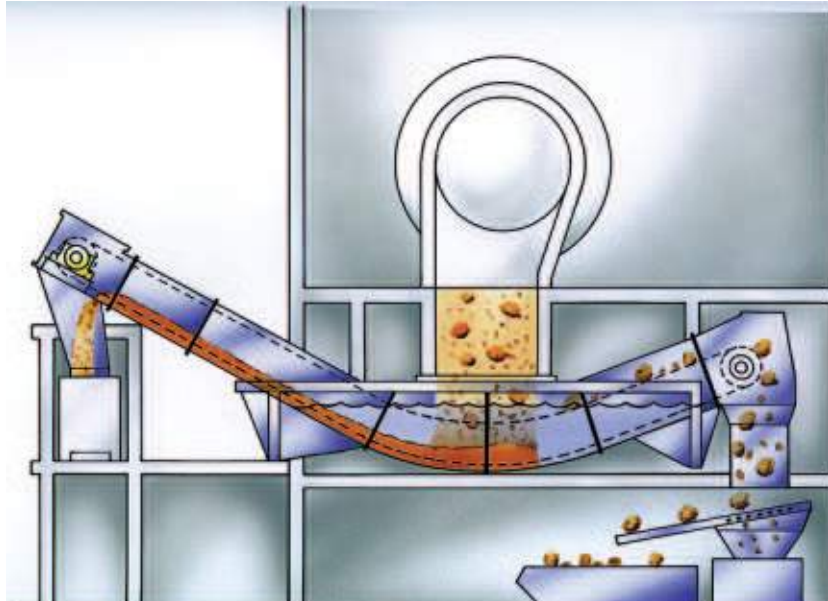

The white cement clinker falls directly from the kiln into the submerged Chain Conveyor for cooling.

Smaller particles passing through the upper chain strand designed like a screen fall onto the trough bottom and are dragged to the discharge at the drive station to be subsequently taken to the mill.

Larger particles remain on the upper chain strand and are taken to the discharge at the take-up station for recycling.

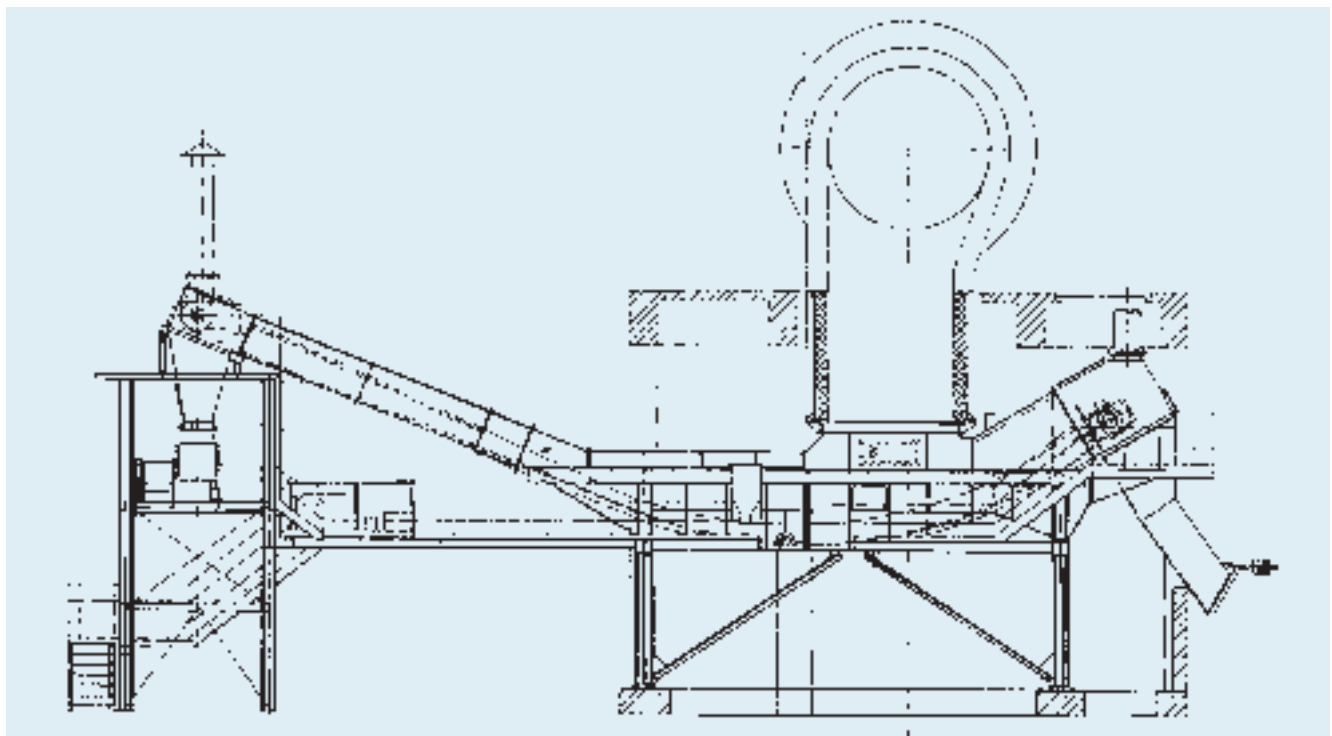

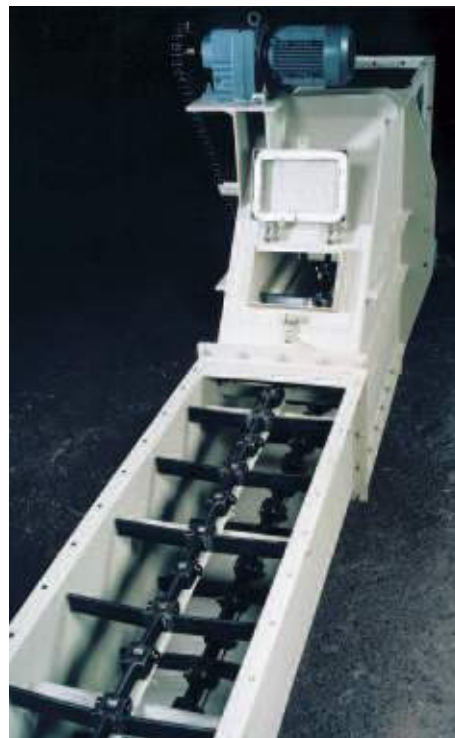
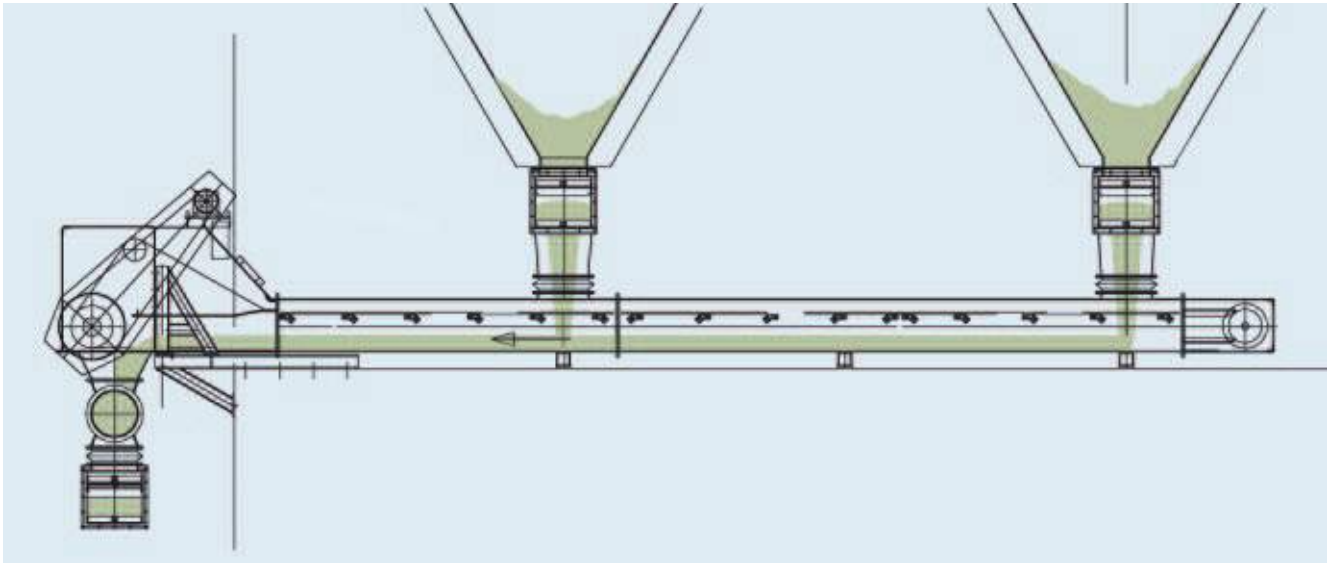

## GRAVITY CHAIN TENSIONING

### Chain Conveyor with gravity chain tensioning for handling filter dust

For the reclaim of fines such as precipitator dust from filter hoppers, the Chain Conveyor with gravity chain tensioning is an economic solution as an integrated or add-on conveyor.

Chain tensioning is achieved by guiding the chain over an idler roller in the drive station, thus causing the chain to sag by its own weight, ensuring perfect fit of the chain around the chain sprocket. With this conveyor design, no tensioning device is required in the return station.

## TENSION STATION

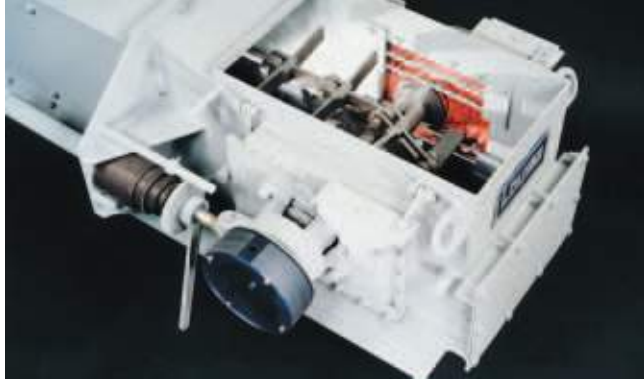

- 1 Chain tensioning device
- 2 Return sprocket
- 3 - 4 Tension bearing
- 5 Hub
- 6 Stuffing boxes
- 7 Speed monitor
- 8 Bearing shield end position
- 9 Chain monitoring
- 10 Reference point for pretension
- 11 Station cover
- 12 Nominal width + 110 mm

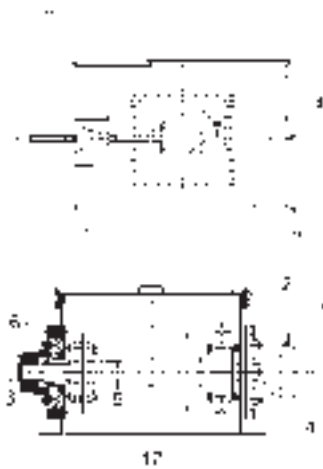

## DRIVE STATION



- 1 Drive sprocket
- 2 Stuffing box
- 3 Pillow block bearing
- 4 Pillow block bearing support
- 5 Outlet flange
- 6 Chain scraper
- 7 Maintenance opening
- 8 Station cover

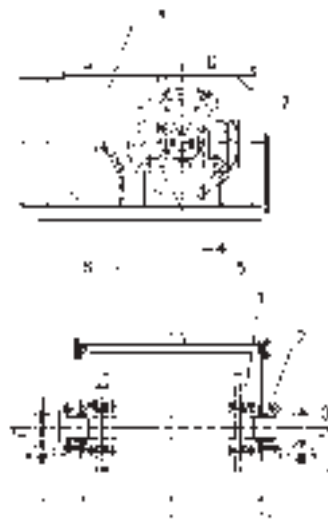

## FORK LINK CHAINS

LOUISE single and double-strand chains are drop-forged and extremely wear-resistant.

Chain links and connecting pins are hardened to 58–60 HRC.

The flights are either welded to the chain links for single-strand chains or fixed with fastening bows on both sides of the chain links for double-strand chains.

The steel used for fabrication of the flights is chosen to suit the bulk material's properties. If abrasive material is to be conveyed, the flights are fabricated from wear-resistant steel.

Standard widths of single-strand chains range from 250 mm to 630 mm. Standard double-strand chains range from 630 mm to 2,000 mm.



Single-strand chain



Double-strand chain

## CHAIN SPROCKETS

The chain sprockets are hardened in areas subject to wear. The sprockets are split into segments as a standard. Therefore, replacement of the sprocket sections does not imply disassembly of the chain strand.

Depending on the load, the sprockets feature six, eight, ten or twelve teeth.

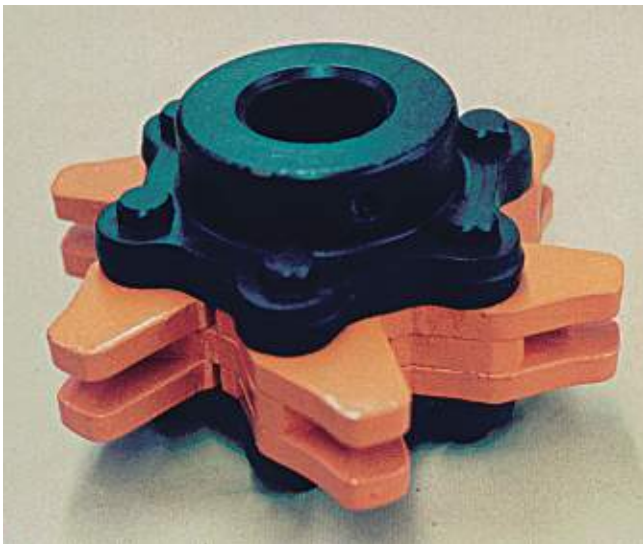

Drive sprocket

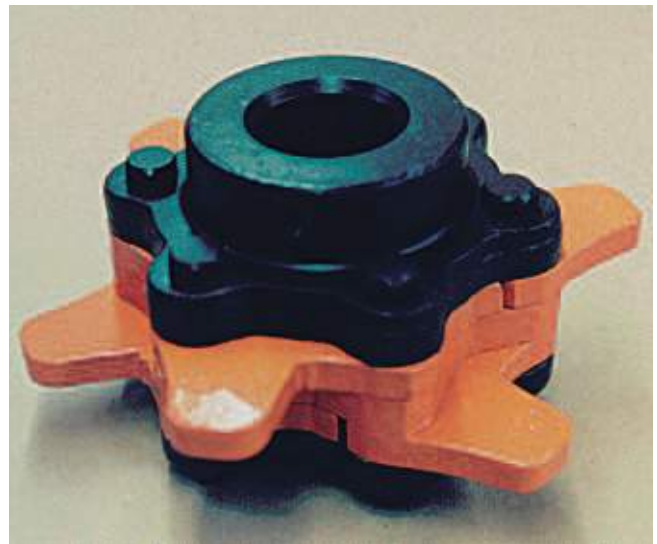

Take-up sprocket

# CONVEYING CAPACITY

The properties of the bulk material are essential to determine the main features of the chain conveyor's components such as chain type or flight height. They

also condition the material layer and the actual conveying capacity. The following capacities are based on standard conditions.

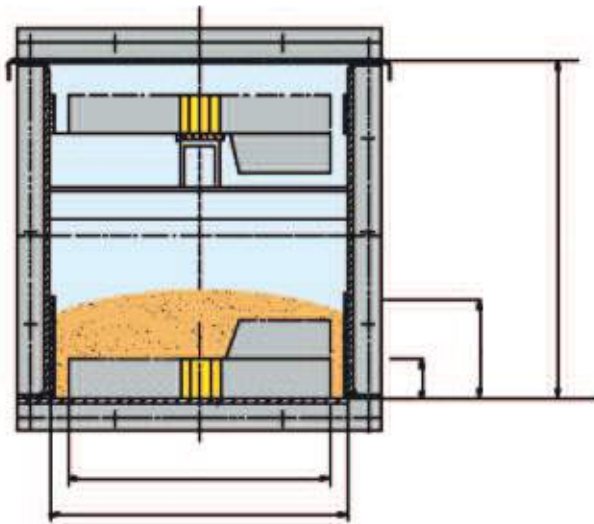

**Single-strand chain**

**Double-strand chain**

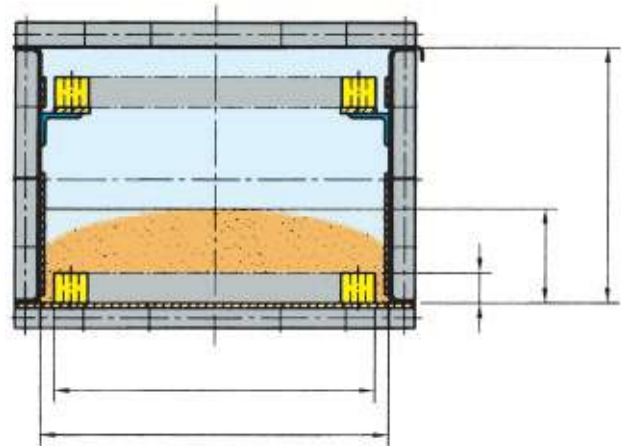

Conveying Capacity with standard conditions										
Width <sup>(1)</sup>	Trough		Material level <sup>(3)</sup>	Flight	Theoretical capacity m <sup>3</sup> /h					
	Width B'	Height <sup>(2)</sup> H			S	Height <sup>(4)</sup> h	Conveying speed m/s			
mm	mm	mm	mm	mm			0,05	0,10	0,15	0,20
250/1	306	515	100	50	5,5	11,0	16,5	22,0	27,5	33,0
400/1	456	515 645	150	50 50	12,5	25,0	37,5	50,0	62,5	75,0
630/1 630/2	686	515 645	170	50 50	20,0	40,0	60,0	80,0	100,0	120,0
800/2	856	515 645	200 230	50 60	29,5 34,5	59 69,0	88,5 103,0	118,0 138,0	147,5 172,5	
1000/2	1056	645 775	230 280	60 60	49,5 51,5	99,0 103,0	148,5 154,5	198,0 206,0	247,5 257,5	
1200/2	1256	645 775	230 280	60 60	50,5 62,0	101,0 124,0	151,5 186,0	202,0 248,0	310,0	
1400/2	1456	645 775	230 280	60 60	59,0 71,5	118,0 143,0	177,0 214,5	236,0 286,0		
1600/2	1656	775	280	80	81,5	163,0	244,5	326,0		
1800/2	1856	775	280	80	91,5	183,0	274,5			
2000/2	2056	775	280	80	102,0	204,0	306,0			



# STANDARD CHAIN CONVEYOR DIMENSIONS

For chains from 250 mm to 1,200 mm width, considering the various chain types and the number of sprocket teeth.

Dimensions for chains with a chain width (B) between 1,200 and 2,000 mm are available on request.

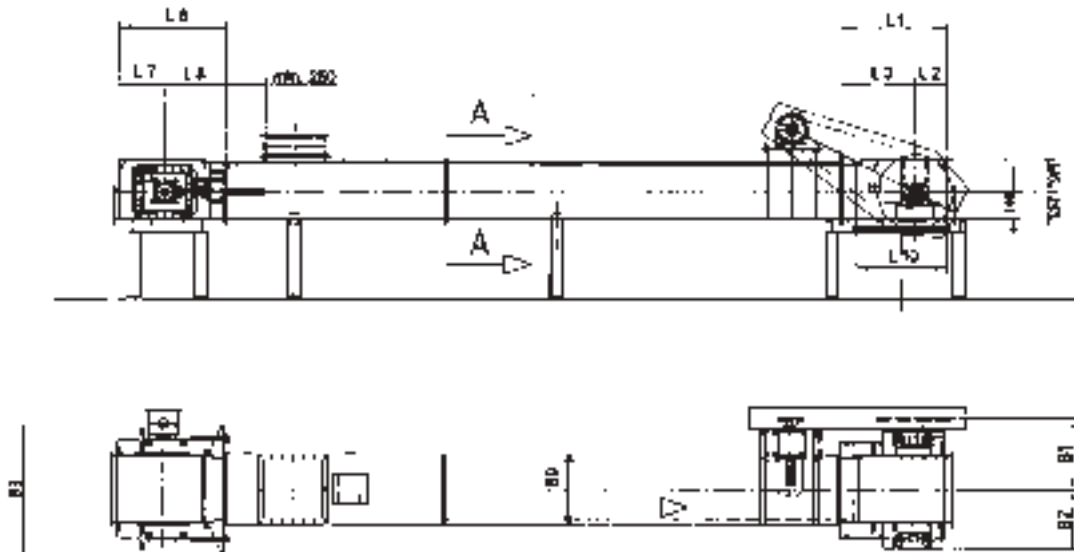

B	Chain	Pitch	Teeth	Bearing Ø	L1	L2	L3	L6	L7	L8	L10	H3	H4	H5	B0	B1	B2	B3
250	40/20	142	6	65/50	1.000	300	700	1.000	600	400	850	273	198	265	413	510	400	660
250	50/25	142	6	65/50	1.000	300	700	1.000	600	400	850	273	198	265	413	510	400	660
250	50/25	142	8	80/60	1.000	300	700	1.000	575	425	850	333	258	310	413	570	435	660
315	50/25	142	6	65/50	1.000	300	700	1.000	600	400	850	273	198	265	481	542	430	725
315	50/25	142	8	80/60	1.000	300	700	1.000	575	425	850	333	258	310	481	602	465	725
400	50/25	142	6	65/60	1.000	300	700	1.000	600	400	850	273	198	265	566	585	475	810
400	50/25	142	8	80/60	1.000	300	700	1.000	575	425	850	333	258	310	566	645	510	810
500	50/25	142	8	80/60	1.000	300	700	1.000	575	425	850	333	258	310	666	695	560	910
500	50/25	142	8	100/75	1.000	300	700	1.000	575	425	850	333	258	310	666	755	595	1.010
630	50/25	142	8	100/75	1.000	300	700	1.000	575	425	850	335	260	310	806	820	660	1.140
630	60/30	200	6	100/75	1.000	300	700	1.000	575	425	850	335	260	310	806	820	660	1.140
630	60/30	200	8	125/75	1.250	350	900	1.000	575	425	1.100	400	360	310	806	870	695	1.140
630	50/25	200	6	125/75	1.000	300	700	1.000	575	425	850	335	260	310	800	940	695	1.140
630	50/25	200	8	150/75	1.250	350	900	1.000	575	425	1.100	400	325	375	800	985	715	1.240
800	50/25	200	6	125/75	1.000	300	700	1.000	575	425	850	335	260	310	990	1.025	780	1.310
800	50/25	200	8	150/75	1.250	350	900	1.000	575	425	1.100	400	325	375	990	1.070	800	1.410
800	60/30	250	6	125/75	1.250	350	900	1.000	575	425	1.100	400	325	375	990	1.025	780	1.310
800	60/30	250	8	150/75	1.500	450	1.050	1.500	800	700	1.350	465	390	440	990	1.070	800	1.410
1.000	60/30	250	6	125/75	1.250	350	900	1.000	575	425	1.100	400	325	375	1.190	1.125	800	1.510
1.000	60/30	250	8	125/75	1.500	450	1.050	1.500	800	700	1.350	465	390	440	1.190	1.125	800	1.510
1.000	60/30	250	8	150/75	1.500	450	1.050	1.500	800	700	1.350	465	390	440	1.190	1.170	900	1.610
1.200	60/30	250	6	125/75	1.250	350	900	1.000	575	425	1.100	400	325	375	1.390	1.225	980	1.710
1.200	60/30	250	8	150/75	1.500	450	1.050	1.500	800	700	1.350	465	390	440	1.390	1.270	1.000	1.810
1.200	60/30	250	8	180/75	1.500	450	1.050	1.500	800	700	1.350	465	390	440	1.390	1.355	1.035	1.810



Installation of new bucket strand

## CONVERSIONS AND REFURBISHMENTS

- **Upgrading of existing plant components**
- **Targeting increased efficiency**
- **Higher output**
- **Improved availability**

With our expert team of engineers planning selective modernisation measures, we pay special attention to the upgrading of existing plant components, targeting increased efficiency, higher output rates and improved availability.

Upgrading of your materials handling and storage equipment to state-of-the-art technology is achieved through a tailor-made refurbishment process under optimum utilisation of time and budget.

Most of the existing components are re-used in the refurbishment process to save cost.

Engineered conversions and refurbishments for increased efficiency and output are performed on AUMUND equipment as well as on the equipment of other manufacturers.



Pre-assembly of chain strands

## AFTER-SALES SERVICES

### • Customer Proximity around the World

At AUMUND, service does not end at the sale of the equipment. It's the beginning of a long-term partnership. AUMUND offers you a full range of services – from commissioning to the delivery of quality spare and wear parts to customized preventive maintenance programs and equipment upgrades. The benefits for you: Maximum equipment efficiency at lower operating costs.

### • Commissioning and Field Service

Today, presence “on the spot” is an absolute “must”. Therefore, our commissioning and service engineers operate from support centers on all continents to guarantee immediate and competent support.

### • Spare and Wear Parts

A comprehensive range of genuine spare parts is available for our entire product range from stocks in Germany, Great Britain and the USA. Our product specialists provide assistance and respond instantly.

### • Retrofits

Aged and worn equipment? Capacity increase needed? Too high operating cost? Aumund “just as new” retrofits are economical and tailor-made solutions for improving your existing equipment at reasonable cost.

### • Preventive Maintenance

Knowing beforehand that service will be needed allows you to schedule downtime and save money with timely repairs. Repairs or retrofits can be accurately anticipated allowing for the downtime to be at the most convenient times and at the lowest possible cost.



## THE AUMUND GROUP

### GERMANY

**AUMUND Fördererbau GmbH**  
Saalhofer Str. 17  
47495 Rheinberg  
Phone: +49 - 2843 - 72 0  
Fax: +49 - 2843 - 6 02 70  
e-mail: aumund@aumund.de  
www.aumund.com

**AUMUND Fördertechnik GmbH**  
Saalhofer Str. 17  
47495 Rheinberg  
Phone: +49 - 2843 - 72 0  
Fax: +49 - 2843 - 6 02 70  
e-mail: aumund@aumund.de  
www.aumund.com

**AUMUND Logistic GmbH**  
Saalhofer Str. 17  
47495 Rheinberg  
Phone: +49 - 2843 - 72 0  
Fax: +49 - 2843 - 72 47 3  
e-mail: logistic@aumund.de  
www.aumund.com

**SCHADE Lagertechnik GmbH**  
Dorstener Straße 360  
44653 Herne  
Phone: +49 - 2325 - 58 74 0  
Fax: +49 - 2325 - 58 74 74  
e-mail: info@schade-lagertechnik.de  
www.schade-lagertechnik.com

### GREAT BRITAIN

**B&W Mechanical Handling Ltd.**  
Gemini House Cambridgeshire  
Business Park, 1 Bartholomew's Walk  
Ely, Cambridgeshire CB7 4EA  
Phone: +44 - 1353 - 665 001  
Fax: +44 - 1353 - 666 734  
e-mail: sales@bwmech.co.uk  
www.bwmech.co.uk

### INDIA

**AUMUND Engineering Private Ltd.**  
2nd Floor, Lakshmi Neela Rite Choice  
Chambers - 9, Bazulla Road,  
T. Nagar Chennai - 600 017  
Phone: +91 - 44 - 4393 63 00  
Fax: +91 - 44 - 2815 60 46  
e-mail: aumund@vsnl.com

### RUSSIA

**AUMUND Representative Office Moscow**  
German-Russian House, Office 44  
ul. Malaja Pirogovskaja 5  
119435 Moscow / Russia  
Phone: +7 495 2879002  
Fax: +7 495 2879006  
e-mail: info@aumund.ru

### HONG KONG SAR

**AUMUND Asia (H.K.) Limited**  
Suite 1301, Oxford House,  
Taikoo Place, 979 King's Road,  
Quarry Bay  
Hong Kong  
Phone: +852 - 3695 - 43 33  
Fax: +852 - 3695 - 43 11  
e-mail: info@aumund-asia.com

### THE NETHERLANDS

**AUMUND Holding B.V.**  
Wilhelminapark 40  
5911 EE Venlo  
Phone: +31 - 77 - 320 01 11  
Fax: +31 - 77 - 320 07 28  
e-mail: info@aumund-holding.nl

### SWITZERLAND

**AUMUND AG**  
Arther Str. 3  
6301 Zug  
Phone: +41 - 41 - 710 10 82  
Fax: +41 - 41 - 710 42 02  
e-mail: info@aumund.ch

### FRANCE

**AUMUND France S.A.R.L.**  
43, rue de Trévise · F 75009 Paris  
Phone: +33 - 1 - 42 46 72 72  
Fax: +33 - 1 - 42 46 72 74  
e-mail: aumund@aumund.fr

### BRAZIL

**AUMUND Ltda.**  
Rua Haddock Lobo, 337 - 11. andar  
01414-001 São Paulo, SP  
Phone: +55 - 11 - 3059 0160  
Fax: +55 - 11 - 3059 0161  
e-mail: aumund@aumund.com.br

### USA

**AUMUND Corporation**  
1825 Barrett Lakes Boulevard  
Barrett Lakes Center II  
Suite 520  
Kennesaw, GA 30144  
Phone: +1 - 770 - 226 - 95 78  
Fax: +1 - 770 - 953 - 48 44  
e-mail: sales@aumundusa.com

### P.R. CHINA

**AUMUND Machinery Trading (Beijing) Co. Ltd.**  
Rm. 7-8, 22-F, East Ocean Centre  
No. 24 Jianguomenwai Avenue  
Chaoyang District  
Beijing 100004  
Phone: +86 - 10 - 65 15 58 13 / 14  
Fax: +86 - 10 - 65 15 58 15  
e-mail: aumund@aumund.cn



AUMUND Headquarters in Rheinberg, Germany

## **AUMUND GROUP**

Your partner for all requirements regarding material handling and storage.  
We design, engineer, manufacture, erect and service reliable equipment.  
Reputation and competence proven by more than 10,000 installations in over 100 countries.

[www.aumund.com](http://www.aumund.com)

**AUMUND Foerdertechnik GmbH · Saalhoffer Str. 17 · 47495 Rheinberg (Germany)**

Tel.: +49 (0)28 43-720 · Fax: +49 (0)28 43-60270 · e-mail: [aumund@aumund.de](mailto:aumund@aumund.de)