



Stormajor™

Radial Boom Stacker

SAMSON
AUMUND GROUP

CONTENT

4	General Applications
8	The Stormajor™ Concept
10	Samson™ Receiving Unit
12	Radial Outloading Boom
14	Stockpile Profiles
16	Dust Control Features
17	Ship Trimming
18	Sizing and Screening
19	Powered Parallel Travel
20	Drive Systems
22	Control Systems
23	After Sales and Services

The Stormajor™ Advantages



- Integral Samson™ Receiving Unit
- Integral Radial Outloading Boom
- Mobile - Easily Positioned
- Receives from both Tipping Truck & Loading Shovel
- Flexible - Stockpiling and Ship Loading
- High Stockpile Capacity
- Fast Ship/Barge Loading
- Electric - Diesel - Gen-Set Drives
- Handles Multiple Materials
- Extensive range of Optional Facilities





Bioenergy, Sweden

General Applications

A unique concept in Bulk Materials Handling, the Stormmajor™ combines the benefits of the Samson™ Material Feeder design with a radial and luffing outloading boom conveyor into a single mobile machine able to receive material both from Tipping Trucks and Loading Shovels.

The Stormmajor™ offers high capacity stockpiling and ship loading from a single integrated machine available with a range of specialised features tailored for each application.

A universal bulk loader, the Conveyor offers very high handling rates within a compact integrated design.

Available with the option of three capacity ranges based on the belt width of the outloading boom conveyor as follows:

- Belt Width - 800 mm:** Rate - 450 m³/h
- Belt Width - 1000 mm:** Rate - 750 m³/h
- Belt Width - 1200 mm:** Rate - 1250 m³/h

For tipping truck deliveries the buffer holding capacity of the integral Samson™ receiving unit allows even faster truck unloading allowing a high average rate to be maintained even taking into account delays in positioning the vehicles.

Available with a wide range of specification options suitable for handling materials from cereals through to heavy mineral ores.

Multiple specification options for maximum flexibility in any application.



Coalite, England



Port of Clyde, Scotland

Port of Clyde

Stockpiling Raw Sugar within an existing warehouse, the sugar is delivered by truck and either tipped direct to the machine or to the floor for subsequent loading to the Stormmajor™ by loading shovel.



Fulchiron France

Loading Silica Sand direct from road tipping trucks to 60 tonne capacity rail wagons, the Stormajor™ includes self propelled, steering travel, to move parallel to the rail and also a radial trimming discharge chute to ensure even distribution of material within the wagon.



Coalite

Stockpiling handling Briquetted Smokeless Fuel operating in an open stockyard, for this application the Samson™ Material Feeder section was fitted with an extended entry to achieve a high volumetric capacity handling the light but abrasive material.



Bioenergy Sweden

Ship loading in the north of Sweden handling wood pellets delivered to the machine from both tipping trucks over the tail section and including an extended entry allowing loading shovels to discharge to each side of the unit simultaneously.



SDH, The Netherlands

General Applications

SDH

Barge Loading dredged sands on the river Rhine received from tipping trucks. The Stormajor™ operates on a river berth with no permanent foundation or concrete base. Using the cantilevered boom design the Stormajor™ may stand on the river bank and load barges moored to a temporary berth using a pontoon between the shore line and the barge.

ACP

Stockpiling and Barge Loading handling coals with the ACP transshipment facility in Amsterdam. This machine is also featured on the cover page.



BHP, Saudi Arabia



ACP, The Netherlands



Material stored within the Samson™ body may be at various load levels along the length of the Samson™



BHP

Stockpiling a wide range of materials from Wood Chip through to Iron Ore in the stockyard of a steel works. The materials are trucked from the port to the and stockpiled in discrete areas. In this application the Stormajor™ is fitted with powered travel including a jacking rear axle with potentiometer steering control system. Other features include a switchable variable speed system to allow the operator to choose the appropriate speed range for the material handled.



The 30 metre long outloading boom allows stockpile heights to 15 metres at a handling rate of 1,000 tonnes per hour.

The Stormajor™ Concept

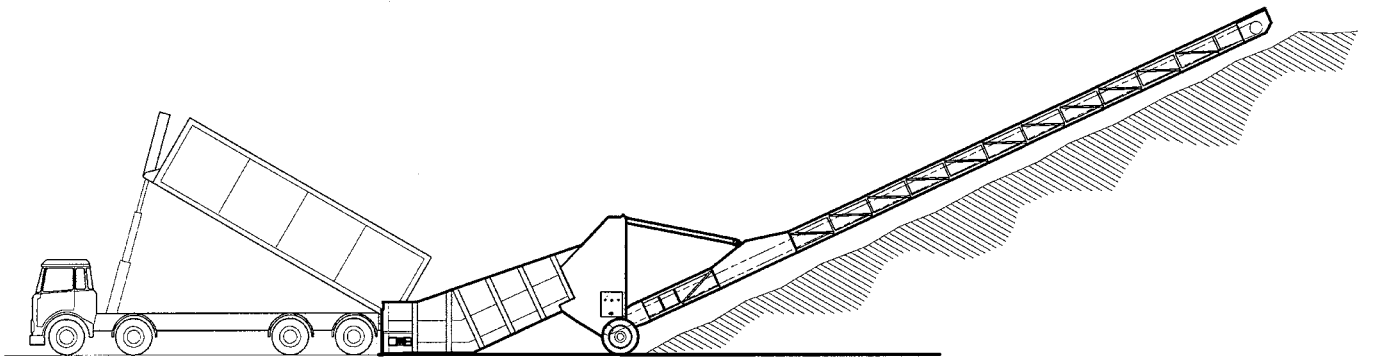

The Stormajor™ Stockpiling

Using the Cantilevered Outloading Boom the Stormajor™ permits high stockpile capacity within compact machine dimensions

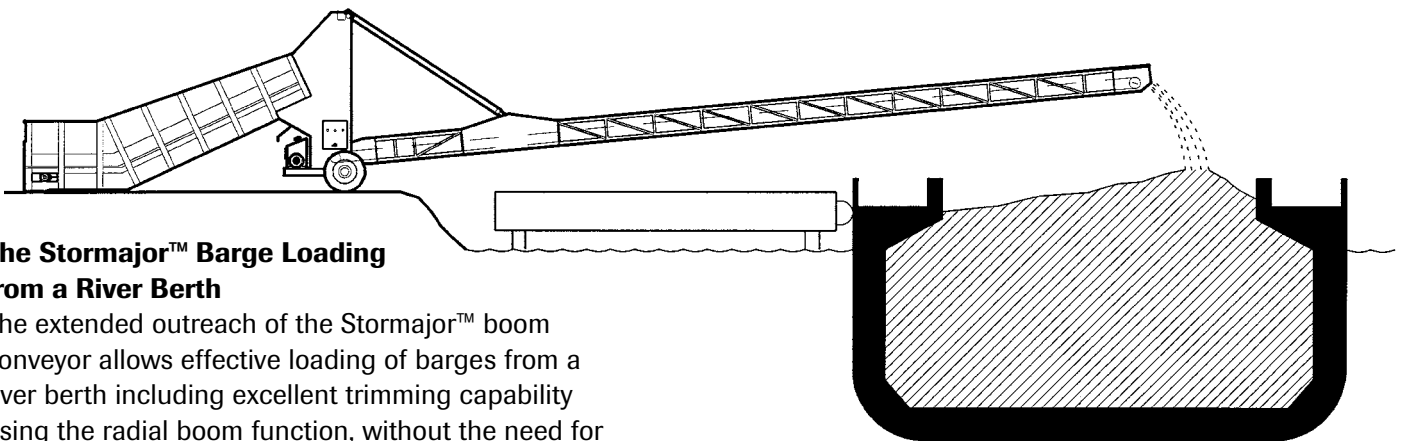

The Stormajor™ Barge Loading from a River Berth

The extended outreach of the Stormajor™ boom conveyor allows effective loading of barges from a river berth including excellent trimming capability using the radial boom function, without the need for permanent civil works

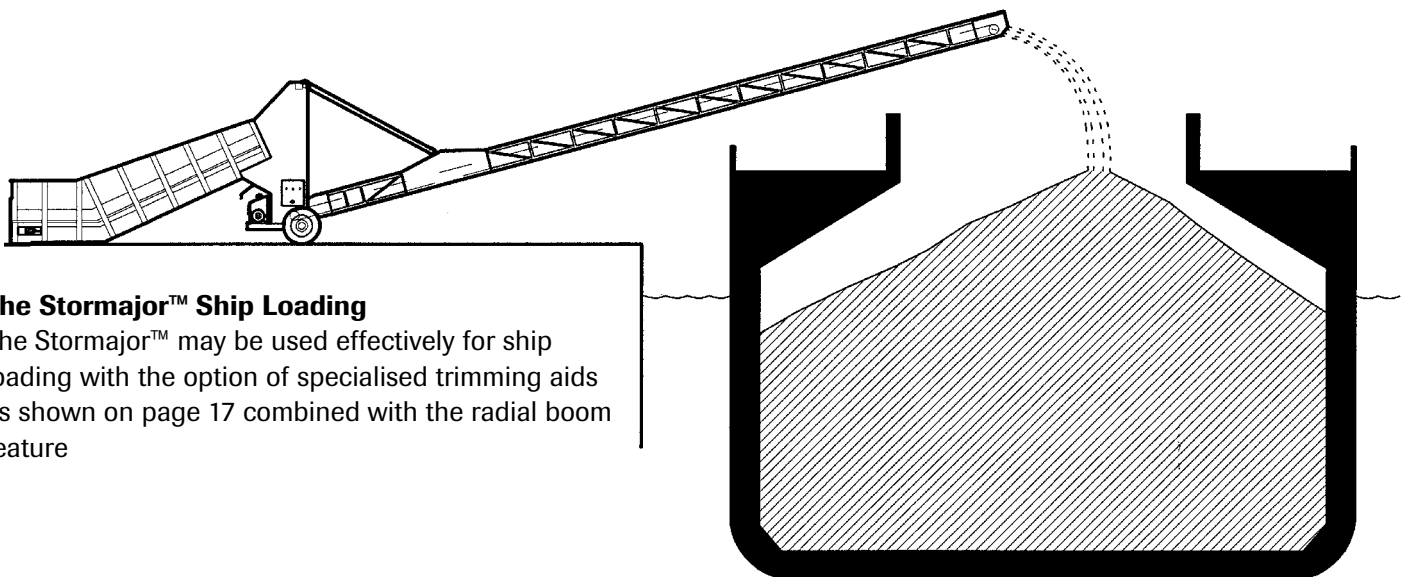

The Stormajor™ Ship Loading

The Stormajor™ may be used effectively for ship loading with the option of specialised trimming aids as shown on page 17 combined with the radial boom feature



Port Talbot Steel Works



Stormmajor™ stockpiling granulated steel slag direct from tipping trucks

The Cantilevered variable angle and radial Outloading Boom combined with the Samson™ design receiving section allows universal application handling most bulk materials direct from tipping trucks or loading shovels.

Using a Chevron Belt the cantilevered outloading boom achieves a high discharge height within compact overall dimensions.



Stormmajor™ handling Silica Sand from tipping trucks to rail wagons

Samson™ Receiving Unit

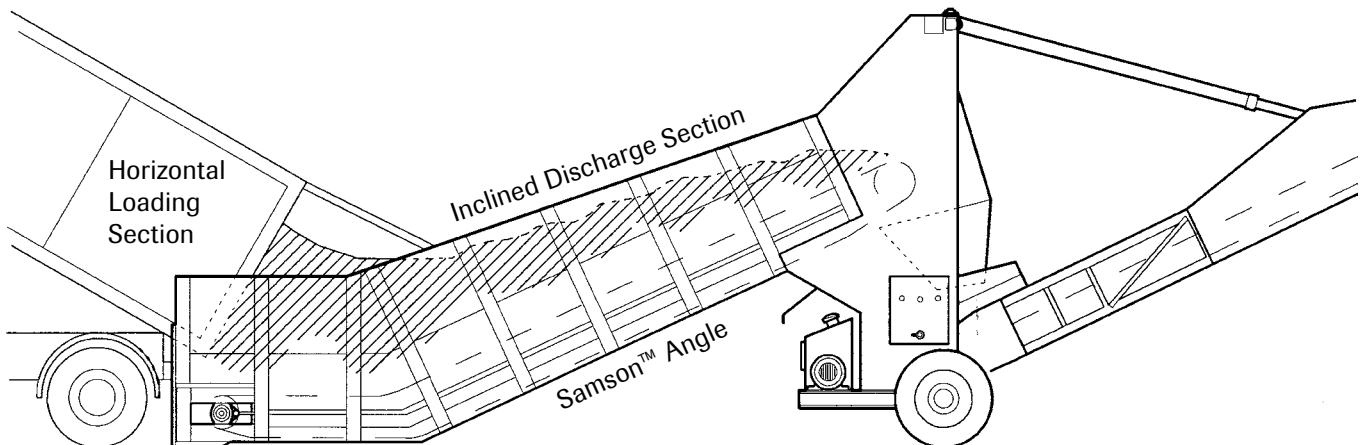

Direct loading from tipping truck and loading shovel

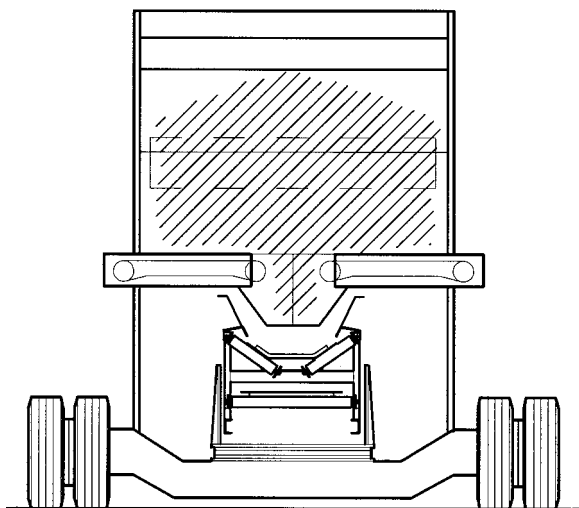

Transfer Chute with Feeder Conveyors for handling wet and sticky materials where the material will not flow on inclined chute surfaces

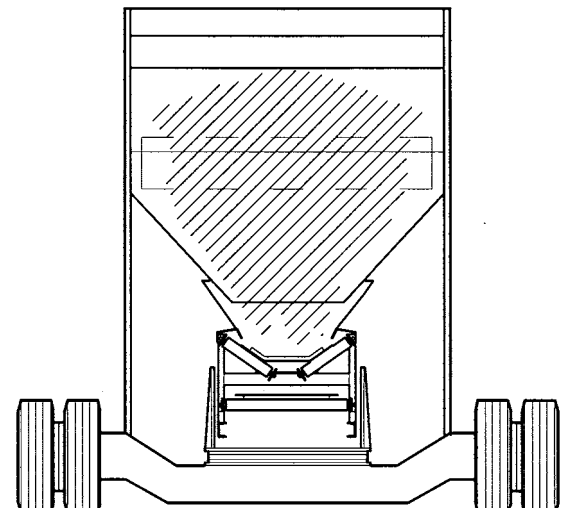

Centralising Chute transfers material from the Samson™ to the radial boom with the option of 25 degree, 45 or 60 degree chute angles

The unique Samson™ Apron Belt Feeder permits the handling of virtually any bulk material providing a buffer holding capacity and controlled rate discharge to the outloading boom conveyor

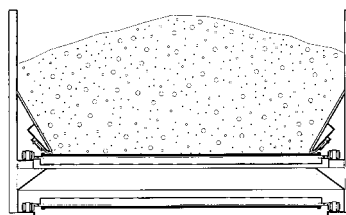

Samson™ Body Section with Apron Belt and Parallel Entry

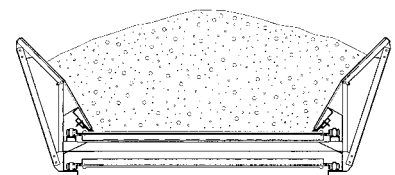

Reinforced Flared Entry Section



Stormmajor™ receives coal from loading shovel for stockpiling and barge loading



Stormmajor™ handling smokeless fuel briquettes direct from tipping trucks



BHP Saudi Arabia



A range of Samson™ receiving unit designs are available based on the standard Apron Belt technology to suit specific application demands.

The machine illustrated top and centre left is handling hot Coke direct from tipping trucks and is provided with an extended entry section with extended side plates providing a high volumetric capacity allowing the complete vehicle contents to be held within the Samson™ body. This unit has a conventional parallel Samson™ entry.

Illustrated above a typical Samson™ centralising chute with 45 degree side angle.

The length, angle and specification of the Samson™ section is determined by the material characteristics and transfer chute angle required to maintain a reliable flow to the outloading boom conveyor.

For free flowing material a reduced Samson™ angle is necessary to prevent runback on the Samson™ inclined section which also effects the transfer chute angle, see the following page for typical specifications.

Illustrated left the Samson™ is fitted with a Reinforced Flared Entry handling coals within a stockyard direct from predominately loading shovels with the option of direct truck loading where required.

Radial Outloading Boom

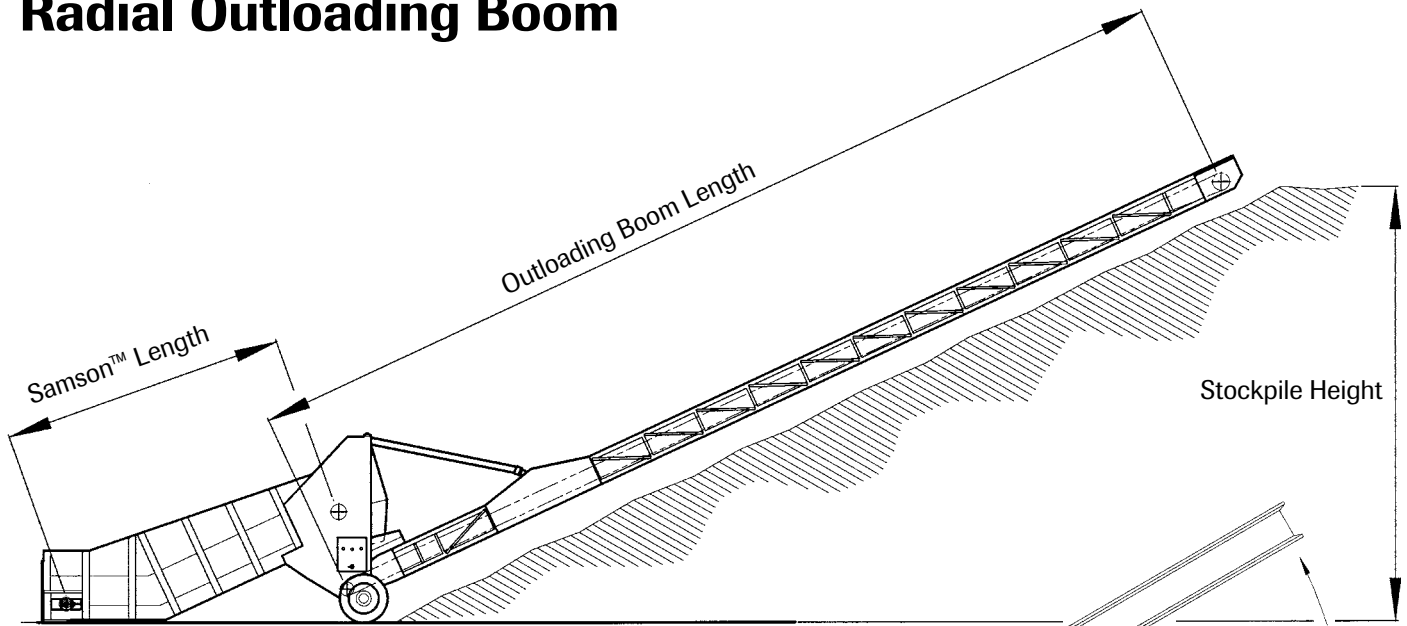

A comprehensive range of outloading boom systems are available. In addition to the standard plus or minus 30 degree slew range alternative configurations are possible up to a full 180 degrees of slewing for special applications.

Two basic boom designs are produced based on a parallel structure with continuous flare plate (as illustrated opposite) for machines up to 24 metres in length and belt widths to 1,000 mm. For larger units and belt widths of up to 1,200 mm a tapered boom structure is provided allowing higher loadings and extended cantilever up to 30 metres boom length.

Slewing Range Plus or Minus 30 degrees

Illustrated below a typical Samson™ design with a 2.0 metre long horizontal receiving section.

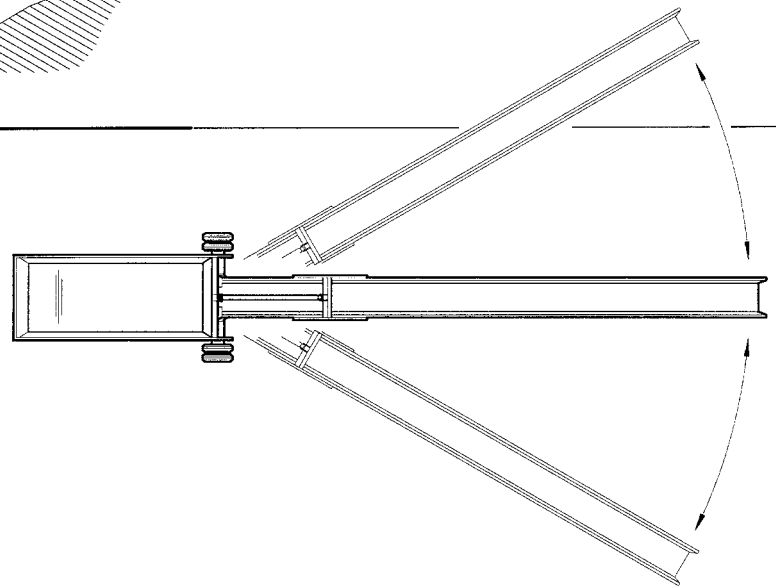

Stockpile Height

Boom Length	Angle 25 deg	Angle 30 deg	Angle 35 deg
15.0 m	7.0 m	8.0 m	8.2 m
18.0 m	8.3 m	9.5 m	10.8 m
21.0 m	9.5 m	11.0 m	12.5 m
24.0 m	10.8 m	12.5 m	14.2 m
27.0 m	12.0 m	14.0 m	16.0 m
30.0 m	13.4 m	15.5 m	17.5 m

Transfer Chute Angle

Samson™ Length	Samson™ Angle	Chute Angle
7.0 m	25 deg	25 deg
8.0 m	20 deg	30 deg
8.0 m	25 deg	45 deg
10.0 m	20 deg	45 deg
10.0 m	25 deg	60 deg
12.0 m	20 deg	60 deg

Alternative designs are available for special applications as shown on the previous pages.



Cantilevered outloading boom with slew ring mount and hydraulic actuator

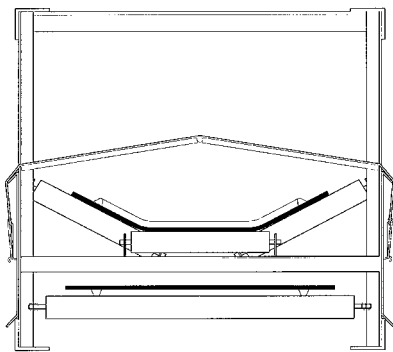

Tapered Boom Section

Suitable for machines over 24 metres boom length and belt widths to 1,200 mm

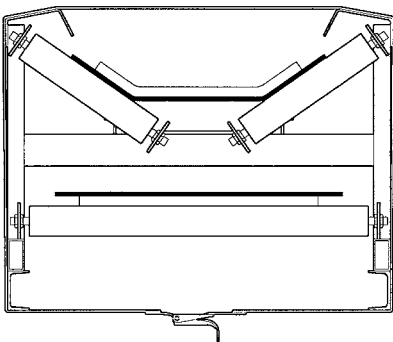

Standard Boom Section

Suitable for machines up to 24 metres boom length and belt widths to 1,000 mm

The cantilevered outloading boom design supported from above allows the complete boom length to overhang the forward axle beam clear of the stockpile.

Using a hydraulic cylinder in tension, a wide angular range may be accommodated allowing the boom to be lowered almost horizontal. At the base the boom is mounted to a precision ball bearing slew ring with hydraulically operated slewing system.

This system allows material with low repose angle to be stockpiled at steep conveyor angles without fear of the material engulfing the main axle wheels.

Outloading boom angles up to 35 degrees are possible using a Chevron Belt where the material handling characteristics permit. In this manner the machine may be compact whilst retaining the maximum stockpile capacity.

All outloading boom designs include three roll troughing idlers with parallel return rolls, all formed integral to the boom structure for minimum weight and maximum structural integrity. At the feed point either close pitch troughing and transition idlers may be provided or for impact resistance handling heavy materials the “Skega” type impact bars may be provided along with an extended feed boot and flexible side seals.

As noted on the previous page the combination of Samson™ length and angle determine the design of the transfer chute between the Samson™ and the outloading boom as illustrated in the table opposite.

Non-Free-Flowing materials require a steep transfer chute and therefore a longer Samson™ inclined section may be necessary to achieve the required chute valley angle. To promote material flow various chute linings are offered including UHMWP, Stainless and Wear Resisting Steel plus Ceramics where highly abrasive materials are handled.

Stockpile Profiles

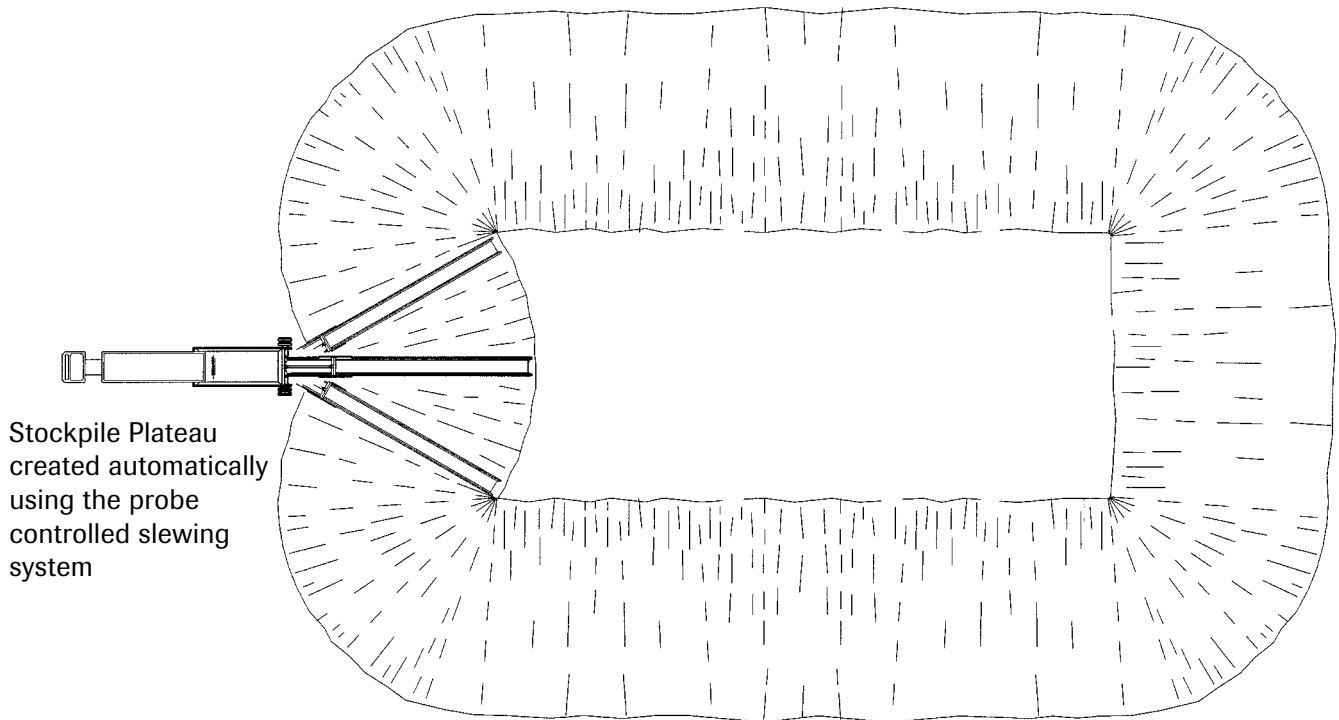

Stockpile Plateau created automatically using the probe controlled slewing system

Using the Radial Boom facility vast stockpiles may be generated with the minimum of machine movements.

As illustrated, the Stormajor™ may be used to generate a substantial stockpile from a single machine position.

By moving the Stormajor™ back in small increments, an extended stockpile may be created with a flat plateau achieving the maximum stored volume within the available floor space.

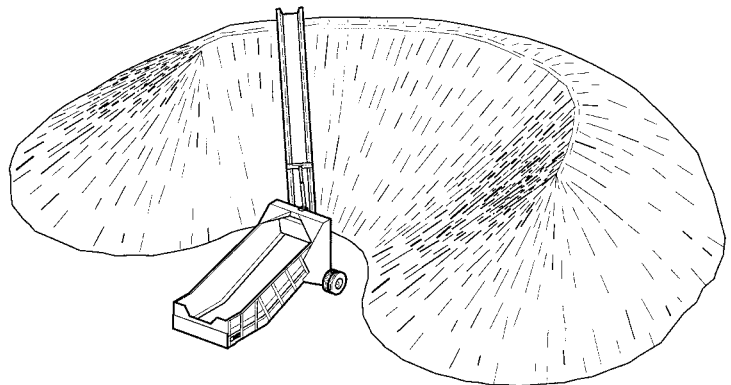

Since the Radial Boom may be lowered to near horizontal, the stockpile may be generated in layers with the boom sweeping over the stockpile with minimum material drop to reduce material degradation and minimise dust generation.

This effect may be used in Heap Leaching applications without the need for expensive fixed conveying installations.

Utilising a stockpile probe the boom slews automatically as the stockpile accumulates, eliminating the need for continual manual intervention.

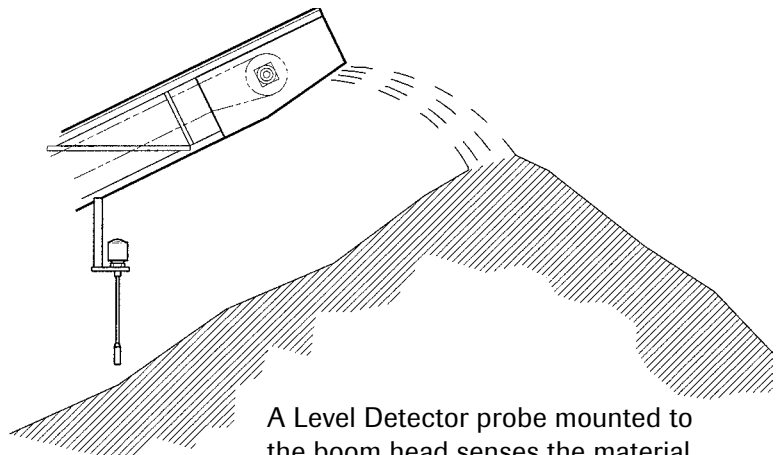

A Level Detector probe mounted to the boom head senses the material level and slews and/or raises the boom automatically



Stormmajor™ stockpiling various materials from wood chip to iron ore for a Middle East steel works stockyard



Stormmajor™ loading cereals to open storage in the Middle East

High capacity stockpiles may be generated using the mobile Stormmajor™ without the need for expensive fixed equipment.

Existing warehouses may be easily converted to bulk stores using the Stormmajor™ loading system, thus minimising capital investment and allowing the effective multiple use of warehouse space.

In new installations the Stormmajor™ offers a low cost solution since there are no machinery loadings applied to the building. Light weight standard portal frame structures may be utilised thus reducing building costs for an economical over-all storage facility.

For outside stockpiles a simple flat surface is all that is required to operate the Stormmajor™ generating large stockpiles without any fixed equipment.

Illustrated below a high specification machine with powered travel is used to stockpile dissimilar materials within a large stacking area offering maximum flexibility.

In this manner a single machine may be used for many different stockpile areas handling different materials with the absolute minimum capital investment.



Stormmajor™ loading cereals to covered flat storage

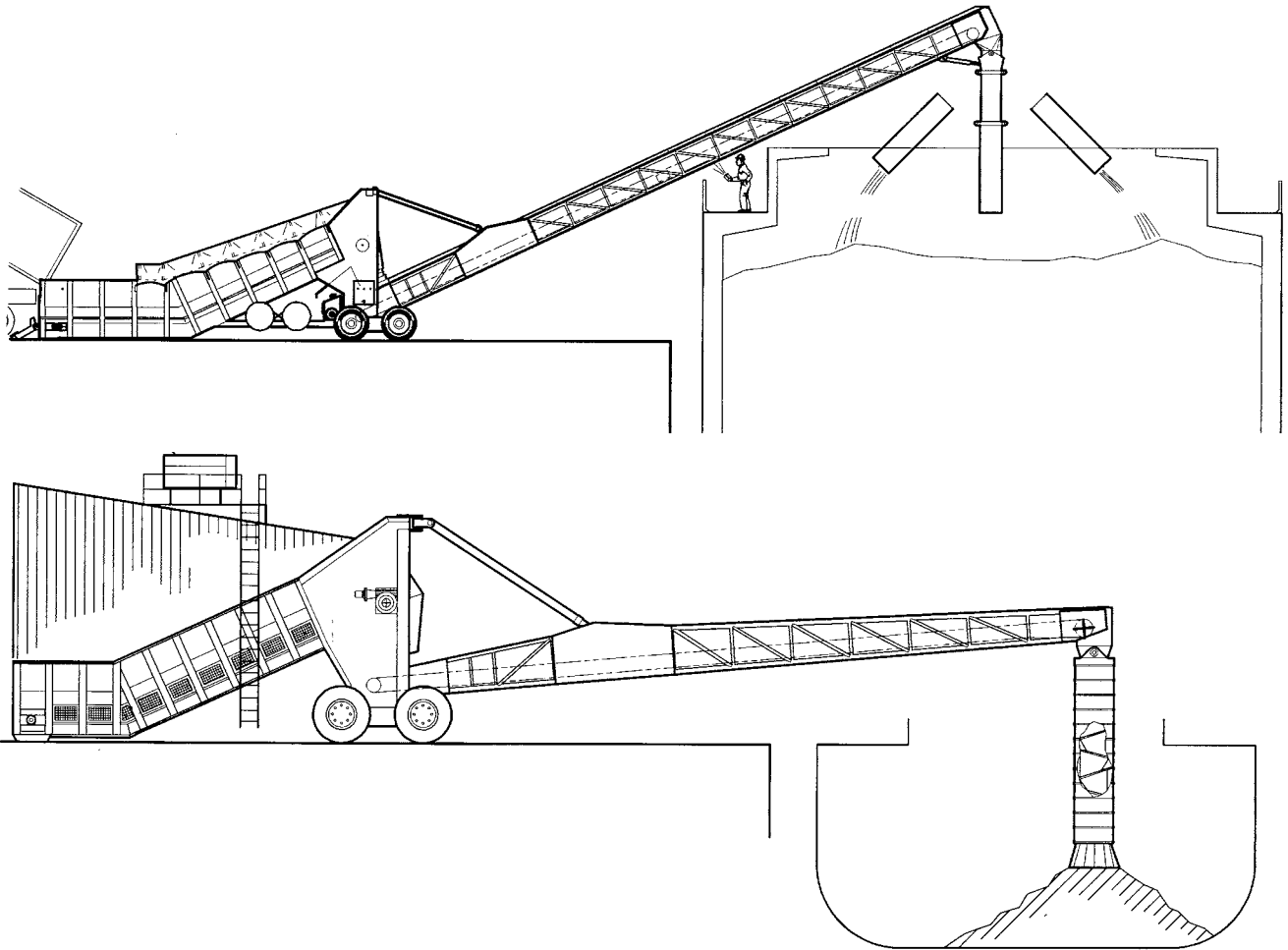

Dust Control Features

A range of enclosure systems with the option of extraction equipment are available for handling dusty materials in sensitive areas.

The Stormajor™ Ship Loading fitted with Flexible PVC Covers for both the Samson™ and Outloading Boom plus a Variable Angle Trimming Chute facility with Infrared Remote Control.

The Stormajor™ Barge Loading fitted with a full profiled steel enclosure to the Samson™ section including dust extraction plus flexible boom covers and a Cascade Dust Controlled loading spout to control the material down to the hold floor.

Transfer Chute Sealing Ring controls dust emissions from the feed boot of the outloading boom conveyor.

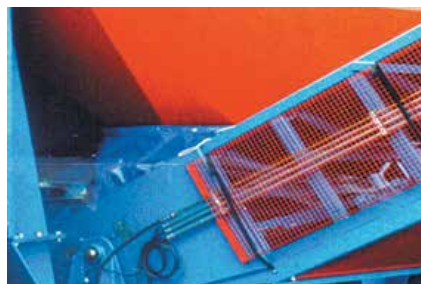



Ship Trimming

For Ship Loading Applications a variable angle chute system is available to allow accurate placement of cargo within the vessel hold.

The machines illustrated here are fitted with an entrainment chute at the conveyor head delivering the material to a variable angle section including a hydraulic actuator providing inward and outward movement of the discharge.

Controls for the chute system are provided at the main machine control cabinet and in addition an Infrared Remote control system may be provided to operate both the trimming chute and boom slew/raise/lower functions from the ship's deck.

Illustrated in the centre photo, stainless steel chute extensions may be provided allowing control of the material trajectory into the vessel hold. These extensions clip to the

base chute part and may be easily removed when not required.

Specifically for Ship Loading the Cambered Boom design as illustrated here allows the head of the conveyor to be lowered over the vessel hold to reduce the free fall distance and minimise the effects of windage on the material flow in-flight.

By combining the variable angle trimming chute and the radial boom function, the Stormajor™ may load and trim barges and small ships effectively with the minimum of machine movements.



Extended Trimming chute showing also the full boom enclosure using flexible PVC covers

Where space is limited and for fast travel along the vessel hold, the parallel travel system (as shown on page 19) provides further improvements in trimming capability and faster overall loading rate by minimising the lost time in machine positioning. For handling dusty cargoes in sensitive areas the Cascade Chute as shown opposite may be installed with a specially reinforced outloading boom to carry the additional imposed loadings.





Sizing and Screening

In-line travel with rear axle steering allows easy positioning within the stockyard with minimum lost time in manoeuvring the equipment.

With larger machines as illustrated here, weighing upwards of 130 tons, powered travel is the only real option allowing the machine to be safely and quickly driven within the stockyard to different stacking areas.

Hydraulic wheel hub motors are employed to drive the machine with integral fail safe brakes.



Jacking Axle shown here with the Samson™ lowered to ground level in the normal working position



Jacking Axle shown here raises the Samson™ clear of the ground for travelling



Twin Axle Steering Bogie with potentiometer alignment system to achieve Ackerman steering without a mechanical linkage.



Rotary Potentiometer linked to the slew ring determines the wheel orientation and maintains both steering wheels in correct alignment using an electronic comparator system.



Hydraulic Actuator Steering System with slew ring mounting for the twin wheel units.



Powered Parallel Travel



Wheel units are mounted to a slew ring with hydraulic actuators to control the wheel alignment from the drivers control position using a Joy-Stick controller linked to variable proportional hydraulic valves allowing variable travel speed

Parallel Travel systems allow movement in any direction and are particularly suited to ship loading applications where the Stormajor™ must move parallel to the vessel for fast trimming.

Parallel travel may be supplied with any size of machine including the Twin Tandem axle systems as shown opposite on larger machines.

Automatic wheel positioning is provided using the rotary potentiometer alignment system, allowing the four wheels to be set at 90 degrees for conventional parallel movement or set at an angle for travel “Crab Fashion” in confined spaces.

For in-line travel the forward wheels are set in the conventional in-line travel position and the rear wheels used to steer the machine.

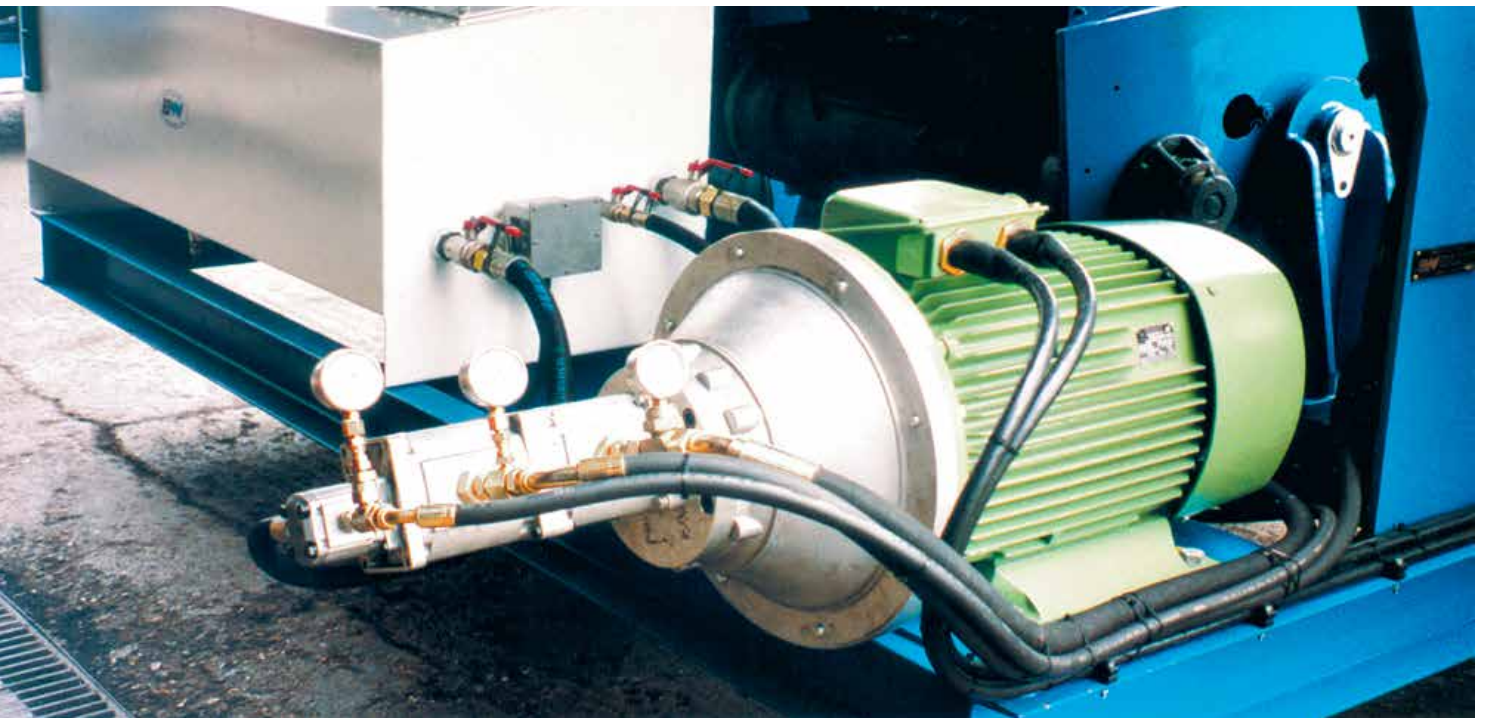

Electric Motor Drive with direct coupled triple section hydraulic pump and reservoir mounted beneath the Samson™ section

Drive Systems

Alternative drive systems are available using electric motor, diesel engine or diesel gen-set prime movers all with hydraulic power transfer to the conveyor drives and for control services.

The use of hydraulic drive permits high power transmission within compact dimensions and allows the prime mover to be located at low level on the main machine chassis for easy maintenance access. This is particularly important for the Radial Boom Conveyor since the hydraulic motor may be mounted at the head pulley for improved drive traction and minimum belt tension.



Diesel motor drive with triple section hydraulic pump system fitted to the side of the main chassis within a sound attenuated enclosure



Deutz Diesel Motor with direct coupled hydraulic drive mounted beneath the Samson™ inclined section



Diesel Gen-Set mounted to the main chassis within a sound attenuated enclosure





Outloading Boom with hydraulic head shaft drive shown here with full enclosure system - loading sand to rail wagons

The flexibility offered by hydraulic power transfer allows simplified maintenance and excellent long term reliability.

Diesel Power

As shown opposite diesel drives are available using either the Deutz air cooled engines or for high power application to 500 kW the Caterpillar range of liquid cooled engines are offered. As shown in these illustrations, the engine is mounted to the main chassis at low level for easy access and maintenance. For machines with a sound attenuated enclosure the engine is mounted to the side of the chassis, otherwise the engine may be mounted beneath the inclined section of the Samson™.

Electric Power

Where mains power is available electric motor drives offer an economical and minimum maintenance solution using a trailing cable between the power supply and the Stormajor™.

Diesel/Electric Power

The large machine illustrated down right on the opposite page is fitted with Diesel Powered Gen-Set drive comprising an engine/generator unit installed within a sound attenuated enclosure mounted directly to the Stormajor™ chassis at low level. This arrangement is ideal where auxiliary services such as control cabin air conditioning and general lighting are required.



Drive to the Samson™ receiving section by direct coupled hydraulic motor with a shaft mounted worm reduction gear

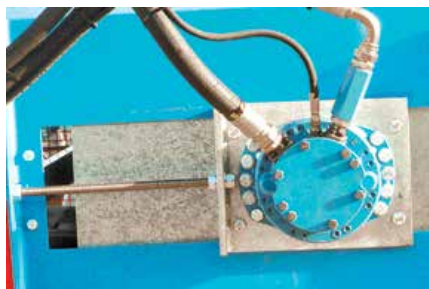

Outloading boom drive with integral radial piston type motor for high power applications



Drive to the head of the outloading boom conveyor with integral Danfoss type

Control Systems

Auto-Feed-Rate Control

To maximise the handling rate of the Stormajor™ the Auto-Feed-Rate system monitors the torque demand and load level of the outloading boom and momentarily inhibits the Samson™ drive to prevent spillage and overloading.

The system comprises solenoid operated control valves on both the Outloading Boom and Samson™ plus the following additional instrumentation - Outloading Boom feed boot level detector, tail shaft rotation sensor and hydraulic pressure detector.

In the event a high material level is detected in the feed boot, or if the belt drive loses traction, or if the drive torque exceeds the set maximum the Samson™ drive is inhibited until the overload condition subsides and is then automatically restarted.

A full range of control systems are available from simple external control panels to a fully integrated control desk with operators air-conditioned cabin.

Three basic levels of Outloading Boom control are offered as follows:

Manual Lever Valves

The simplest form of control with direct acting level operated hydraulic valves to control the outloading boom raise/lower and slew left/right. Using this system, the operator may adjust the discharge point manually only.

Solenoid Operated Valves

For applications requiring automatic stockpile control or remote operation the boom raise/lower and slew control valves are solenoid operated with press buttons at the control panel with the option of remote operation.

Conveyor Drive Control

The standard control system includes rotary flow control valves (as illustrated below) which allow control of the Samson™ and out-loading boom belt speed plus (by setting the flow control to zero speed) providing off-load starting. As an option, solenoid operated valves may be provided for these services allowing the Samson™ and Outloading Boom to be started from press-buttons on the main control panel.



External control panel for electric motor drive with detachable cable



External control panel for diesel motor drive showing local engine key switch starting control without full instrumentation



Control cabins may be mounted at high level as shown above or at low level on the main chassis

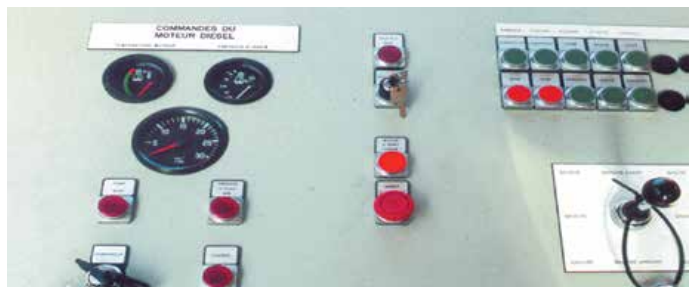

Comprehensive control panel with integral diesel motor instrumentation and joy stick controller for powered travel system operation

After Sales and Services

SAMSON Materials Handling Ltd. strive to deliver the highest standards of customer support and after sales service worldwide with the collaboration of the local AUMUND Group daughter companies and representative offices and including:

- Application advice
- Port or Plant Infrastructure Survey
- Performance and Selection Criteria
- Operational Guidance
- Machine Selection and Specification
- Supervision of Site Assembly
- Commissioning
- Advice on Maintenance Programmes
- Rebuilding and Refurbishment
- Genuine Spare Parts
- Service Contracts

Our engineers are highly trained and experienced in the SAMSON Materials Handling products and familiar with port operations and the demands of shipping schedules where equipment availability is critical to avoid demurrage costs.



THE AUMUND GROUP

GERMANY

AUMUND Fördertechnik GmbH

Saalhoffer Str. 17
47495 Rheinberg
Phone: +49 - 2843 - 72 0
Fax: +49 - 2843 - 6 02 70
e-mail: aumund@aumund.de
www.aumund.com

Aumund Logistic GmbH

Saalhoffer Str. 17
47495 Rheinberg
Phone: +49 - 2843 - 72 0
Fax: +49 - 2843 - 7 24 73
e-mail: logistic@aumund.de
www.aumund.com

SCHADE Lagertechnik GmbH

Dorstener Straße 360
44653 Herne
Phone: +49 - 2325 - 58 74 0
Fax: +49 - 2325 - 58 74 74
e-mail:
info@schade-lagertechnik.de
www.schade-lagertechnik.com

GREAT BRITAIN

SAMSON Materials Handling Ltd.

Gemini House Cambridgeshire
Business Park, 1 Bartholomew's Walk
Ely, Cambridgeshire CB7 4EA
Phone: +44 - 1353 - 665 001
Fax: +44 - 1353 - 666 734
e-mail: sales@samson-mh.com
www.samson-mh.com

INDIA

AUMUND Engineering Private Ltd.

2nd Floor, Lakshmi Neela Rite Choice
Chambers · 9, Bazulla Road,
T. Nagar Chennai - 600 017
Phone: +91 - 44 - 4393 63 00
Fax: +91 - 44 - 2815 60 46
e-mail: aumund@vsnl.com

HONG KONG SAR

AUMUND Asia (H.K.) Limited

Unit 3B & 5, 30/F.
148 Electric Road
North Point
Hong Kong
Phone: +852 - 3695 - 43 33
Fax: +852 - 3695 - 43 11
e-mail: info@aumund-asia.com

DUBAI U.A.E.

AUMUND Fördertechnik GmbH Representative Office

P.O. Box 35291
Dubai, UAE
Phone: +971 - 4 - 2823762
e-mail: catalina@aumund.com

THE NETHERLANDS

AUMUND Holding B.V.

Wilhelminapark 40
5911 EE Venlo
Phone: +31 - 77 - 320 01 11
Fax: +31 - 77 - 320 07 28
e-mail: info@aumund-holding.nl

SWITZERLAND

AUMUND AG

Arther Str. 3
6301 Zug
Phone: +41 - 41 - 710 10 82
Fax: +41 - 41 - 710 42 02
e-mail: info@aumund.ch

RUSSIA

AUMUND Representative Office

German-Russian House, Office 44
ul. Malaja Pirogovskaja 5
119435 Moscow / Russia
Phone: +7 - 495 - 287 90 02
Fax: +7 - 495 - 287 90 06
e-mail: info@aumund.ru

FRANCE

AUMUND France S.A.R.L.

43, rue de Trévisse · F 75009 Paris
Phone: +33 - 1 - 42 46 72 72
Fax: +33 - 1 - 42 46 72 74
e-mail: aumund@aumund.fr

BRAZIL

AUMUND Ltda.

Avenida Eng. Luis Carlos Berrini
716 - 4.andar - conj. 41
04571-000 - São Paulo / SP
Phone: +55 - 11 - 3059 0160
Fax: +55 - 11 - 3059 0161
e-mail: aumund@aumund.com.br

USA

AUMUND Corporation

1825 Barrett Lakes Boulevard
Barrett Lakes Center II
Suite 520
Kennesaw, GA 30144
Phone: +1 - 770 - 226 - 95 78
Fax: +1 - 770 - 953 - 48 44
e-mail: sales@aumundusa.com

P.R. CHINA

AUMUND Machinery Trading (Beijing) Co. Ltd.

Rm. 7-8, 22-F, East Ocean Centre
No. 24 Jianguomenwai Avenue
Chaoyang District
Beijing 100004
Phone: +86 - 10 - 65 15 58 13 / 14
Fax: +86 - 10 - 65 15 58 15
e-mail: aumund@aumund.cn



SAMSON office building Ely, U.K.

AUMUND GROUP Headquarters in Rheinberg, Germany

SAMSON

AUMUNDGROUP

Dedicated to providing the most comprehensive range of mobile solutions for bulk materials handling in Ports and Terminals, Mining, Environmental, Cement, Foodstuffs, Agriculture and Power.

Built around the unique concept of the Samson™ Material Feeder, SAMSON Materials Handling offer flexibility, reliability, quality, and industry leading performance from truck intake right through to mobile stacking and ship loading solution.

SAMSON Materials Handling Ltd.

Gemini House, Cambridgeshire Business Park, 1 Bartholomew's Walk, Ely, Cambridgeshire CB7 4EA, England

Tel.: +44-1353-665001 • Fax: +44-1353-666734 • e-mail: sales@samson-mh.com

www.samson-mh.com