

SPECIAL FAN DESIGNS



PLANT-SPECIFIC
FOR MAXIMUM EFFICIENCY

scheuch
TECHNOLOGY FOR CLEAN AIR

CORRECT PLANT CONCEPT FOR PERFECT FAN SPECIFICATION

The fan is the core component of every piece of equipment used for extraction, dedusting, the cleaning of exhaust and flue gases, or the pneumatic transport of materials.

As an equipment and plant manufacturer, we have the process know-how and a thorough understanding of the special requirements for different applications. This expertise makes it possible for us to assume full responsibility, without interface problems, for the right plant concept with its individual components. This in turn provides the basis for a perfect fan specification and a bottom line that ensures the highest levels of operational availability, economical operation and a long service life.

The first step is to determine the most important data. This includes, for example, information about the volume flow, pressure increase, the type of transport medium, and whether crude gas, dust-laden gas or other material is to be transported. This information provides the basis for the specification of the impeller design, the intake velocity, the impeller's rotational speed and the type of drive unit (direct drive, drive through coupling

or belt drive). In addition, other information is also required such as the ambient temperature and elevation above mean sea level, the number of fan run-ups or cold starts per day, explosion protection and noise emission limits.

We use our own in-house EDP programs to support this process of precision customer-specific fan design. The programs optimize and adapt the design to the plant characteristics and take into account such criteria as efficiency, rotational speed, power output, and wear and tear. Data for noise levels and the motor run-up time are also calculated.

As the result of the close collaboration between customers and our employees in technical sales, process engineering, project management, commissioning and after-sales service, we receive a wealth of information and up-to-date feedback about real-world applications in many different branches. This information flows directly into our ongoing process of product development and optimization so that a fan from Scheuch will always remain a special fan that has been perfectly specified for the respective plant concept.



MINIMAL POWER REQUIREMENTS FOR HIGH PLANT EFFICIENCY

The proper design of the fan has a significant and positive impact on the capital investment and operating costs. Saving just 1 kW of energy, for example, translates into annual electricity savings of 500 Euros for a three-shift industrial plant.

Energy Efficiency Through A Wide Range Of Fan Types

Our fan program is divided into a finely tuned range of model types. Taking into account the relationship between the total pressure increase and volume flow, this makes it possible to select from many different models and choose the right fan for the optimal operating point with the best energy conversion factor for highest energy efficiency.

Increased Energy Efficiency Using Flow Optimization

The incoming flow conditions have a significant influence on a fan's efficiency and energy consumption. During the planning phase, we attach great importance to optimizing the incoming and outgoing airflow. With the help of CFD (Computational Fluid Dynamics) simulations, we are able to optimize the incoming airflow for situations where space is limited by performing calculations for a variety of baffle plate configurations.

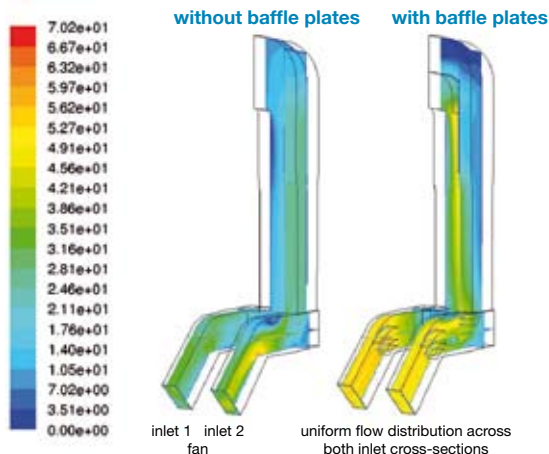

CFD simulation of the incoming airflow of a double-inlet fan.

Energy Efficiency Through Speed Control

Scheuch has used electronic frequency converters since the early 1990's to control fan speeds. Speed control is recommended especially for applications where operating conditions change frequently or where the time spent in partial load operation accounts for a significant portion of the total operating time. The higher capital costs associated with variable frequency drives can normally be justified by lower energy costs in just a few years.

Because of the orientation of the speed control on the plant characteristics, the energy consumption is minimised according to the respective demands.

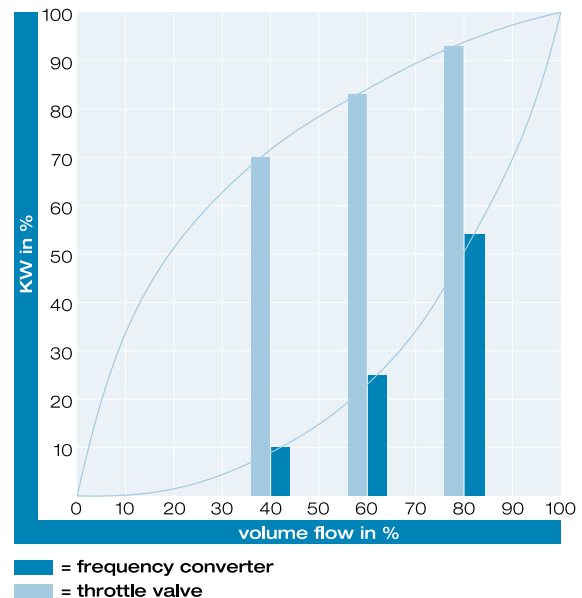

Energy efficiency achieved by adapting the energy requirements as a function of volume flow.

Reducing the rotational speed of a fan leads to more favorable noise emission values and generally results in less wear and tear. A frequency converter also ensures smoother start-up of the fan with no current peaks; only a maximum of 1.1 times the rated current is required. Smaller dimensioning of motors and electrical systems makes it possible to achieve substantial cost savings.

HIGH OPERATIONAL AVAILABILITY AND LONG SERVICE LIFE

Our comprehensive know-how as a plant and equipment manufacturer, developed over nearly 50 years, assures high operational availability and long service lifetime for the fans. Right from the start, we rely on rigorous development work and our own engineering and R&D departments. Our own Technikum, or Tech Center, features the most modern and continuously updated equipment, allowing us to continuously test and optimize the best available technology for the benefit of our customers.

More Safety Through Computational Models

When applications are especially mission-critical, we also use stress analyses and computational modeling to examine factors such as equivalent stresses and the deformation of an impeller as the basis for optimization of geometries and material selection.

With the help of the Finite Element Method (FEM), for example, we perform a mathematical analysis of the pressure surge resistance and then verify this result under the specified conditions in hands-on testing in our own test center.

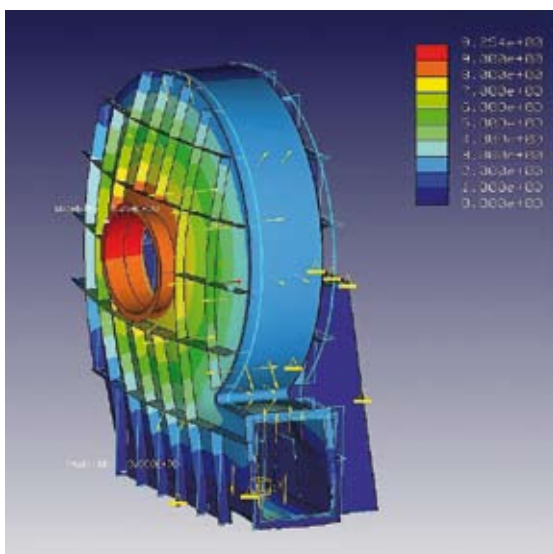

FEM analysis of a pressure surge resistant fan.

Long Service Life Through Wear-Protection

In order to lower maintenance costs and increase equipment availability by increasing maintenance intervals, Scheuch has implemented preventive wear-protection measures based on practical experience. This includes the use of resurface welding — either partial or full surface — to significantly increase the service life of fan impellers exposed to airflows transporting solid materials.



Impeller protected by resurface welding.

Comprehensive Measures for High Operating Safety

We offer many types of safety devices including devices to monitor vibration, speed and bearing temperatures, as well as permanent lubrication systems that Scheuch provides as standard equipment for certain applications. Also noteworthy is a comprehensive service program for preventive maintenance that includes functional inspections, performance measurements, measurements of noise levels, monitoring of vibration levels, bearing inspections, on-site balancing of impellers, and maintenance contracts.

QUALITY ASSURANCE THROUGH IN-HOUSE MANUFACTURING

Scheuch has developed and built radial fans since the company was founded in 1963. Because each fan has its own specific design, no two fans are alike. For reasons of quality assurance, the production process focuses on single-piece production. The timely development and integration of CAE/CAD ensures a continuous flow of data from the bidding process and order specification phase to computer-assisted generation of production documents for production planning and control and even delivery specifications. We manufacture as many as 3,000 fans annually.

State-Of-The-Art Welding Technology

The welding of high-strength materials for fan impellers, or to provide anti-wear protection for fan impellers and fan casings, requires superbly trained, highly qualified employees who are proficient in modern welding techniques and who can process different levels of material quality with the highest precision. Six of our employees are EWE-qualified (European Welding Engineer) or EWT-qualified (European Welding Technologist). In order to achieve the required manufacturing quality, all of the steps in the work and testing process must be precisely followed and documented according to the so-called Welding Procedure Specification.



Fast Service

Our independent fan production unit has a modern machining center. With this machining center, it is now possible to turn all fan shafts in house. This guarantees fast reaction times in the event of

damage and ensures that a new shaft or impeller in standard configuration can be supplied for the repair within a single day.



Individual Testing and Confirmation

Each fan is subjected to a precision check of its functional characteristics and an in-house inspection. The inspection includes, for example, a check of the fan geometry, the make of motor, power consumption when closed and when partially opened, vibration characteristics, and the temperature of the bearings over an extended period of time.

Our Certifications Are The Basic of Our Quality Assurance Program

- Quality management according to ISO 9001 and ATEX
- Development, configuration, manufacturing and sale of ventilation components and equipment according to ISO 3834-2:2005 (previously EN 792-2)
- Manufacturer welding qualification according to DIN 18800-7, Class E
- IIW International Institute of Welding (EWE-IWE)
- Non-destructive materials testing: PT and UT Level 2



A CUSTOM FAN PROGRAM FROM AN EXPERT IN VENTILATION TECHNOLOGY

Based on its experience with roughly 40,000 fans in different industrial sectors, Scheuch developed a comprehensive and technically mature fan program over the years: 1,500 fan types in 12 model lines with pressure increases ranging from 1,000 Pa to 20,000 Pa and volume flows of 500 to 650,000 Am³/hour. The speed range lies between 530 and 3600 rpm. The position of the casing determines the direction of the fan exhaust and can be selected in increments of 45°.

A balance quality of $Q = 2.5$ is standard for all impellers. Depending on the demands, different kinds of anti-wear protection are available.

Special designs

Various fan designs are developed to solve unique challenges. Examples include:

- Hot gas designs for applications up to 550° C
- Pressure surge resistant designs for transporting explosive gas mixtures
- Gas-tight designs
- Two-stage designs for high-pressure applications
- Rubberized or plastic-coated radial fans for chemically aggressive media



Direct drive



Belt drive



Drive through coupling

Noise Insulation

Our know-how in the field of acoustical engineering is incorporated at an early stage into the fan construction and development process. For additional noise reduction, we offer primary and secondary measures including pipe sound absorbers, sound suppression cabins featuring flexible connections and assembly, or designs with acoustically engineered casings.

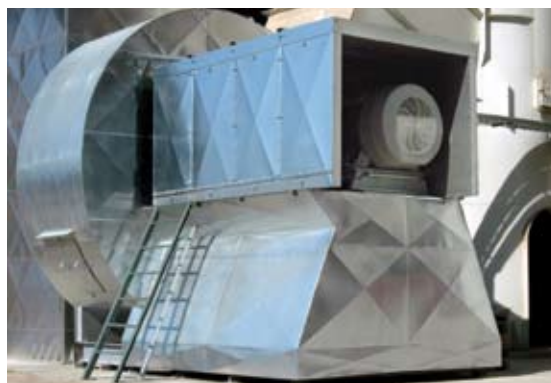

Fan with noise reduction measures.

Drive Types

The type of drive unit is determined by the requirements of the application: **Direct drive** for motor outputs up to 160 kW and maximum temperatures of 200° C, compact construction with reduced loss of efficiency via the drive unit. **Belt drive** with fine speed adjustment via V-belt pulleys, used as extraction or transport fans up to 1,000 kW. **Drive through coupling** for the performance range up to 2,500 kW as well as **double-sided bearings** for the impellers upon customer request.

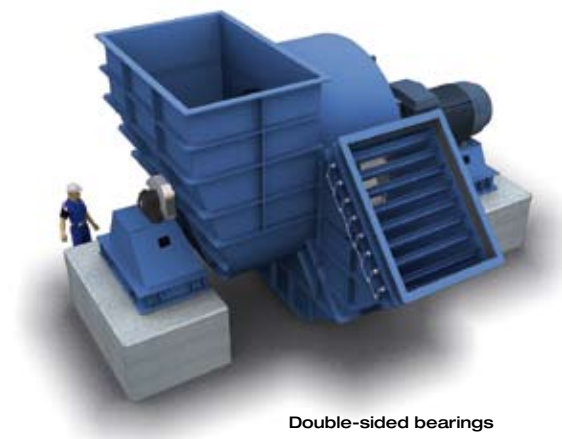

Double-sided bearings

THE RIGHT FAN FOR SPECIFIC APPLICATION AREAS



Compact mass-produced fan for machine construction



Transport fans for group extraction system



Stainless steel components for special media



Transport fan with belt drive



Fans with coupling drive



Process fan in the manufacturing



Process fan with double-sided bearings

WE'RE AT YOUR SERVICE FROM THE WORD "GO"

Our team of specialists is there to serve you with a comprehensive service and support program that ranges from qualified consulting on a fan's optimal design with respect to the operating point, plant characteristics, efficiency, wear and tear, and power consumption to

- Assembly, commissioning, final acceptance, performance measurements, functional checks
- Training of customer employees
- Upgrades to increase performance and safety

- CFD simulations for flow optimization
- Sound analyses, expert opinions and suggested solutions
- Maintenance contracts and remote monitoring
- Preventive maintenance through vibration measurement, bearing inspections and on-site balancing of impellers
- Express delivery service for replacement impellers.

Service-Hotline [+43/7752/905-905](tel:+437752905905)



scheuch
TECHNOLOGY FOR CLEAN AIR