



Samson™ Material Feeder

Bulk Materials Receiving Unit

SAMSON
AUMUND GROUP

CONTENT

- 3 Surface Installation
- 4 The Samson™ Material Feeder Solution
- 5 Universal Application
- 6 Operational Concept
- 7 Discharge Rate Control
- 8 Body & Entry Designs
- 9 Samson™ Material Feeder Construction
- 10 Dust & Fume Control
- 11 Enclosure Systems
- 12 Discharge Interface
- 13 Feeder Options
- 14 Alternative Fuels
- 15 Mechanical Drive
- 16 Instrumentation
- 17 Electrical Controls
- 18 Sizing and Screening
- 19 Storage Solutions
- 20 Under Floor Options
- 21 Railcar Discharge
- 22 Related Products
- 23 After Sales & Services

A Unique Concept

SAMSON Materials Handling Ltd. developed the Samson™ Material Feeder concept to satisfy the demands of clients requiring a mobile solution to receive general bulk materials such as coal and aggregates direct from tipping trucks in mainly Ship Loading applications and, where fixed plant was not a viable option.

The Samson™ Material Feeder concept eliminated the need for any truck ramps, or fixed civil work and was rapidly extended to fixed plant projects where the flexibility of surface installation is a clear benefit. This is particularly realised in port applications where the high ground water level makes conventional underground pits expensive to construct and maintain.



Samson™ Material Feeder integrated to a Mobile Shiploader receives Copper and Gold concentrate



Mobile Samson™ Material Feeder receives as-mined Limestone from articulated trucks



Samson™ Material Feeder Clinker Intake for Cement Grinding Plant with integrated Dust Extraction



Twin Samson™ Material Feeders receive minus 25 mm Limestone for the Flue Gas De-Sulphurisation system in an US American Power Plant

Surface Installation



Samson™ Material Feeder raised discharge permits transfer direct to surface mounted belt conveyor



The Samson™ Material Feeder provides a compact solution in this intake facility for crushed Limestone. Being delivered by trucks to the power plant working on a merry-go-round basis from a local quarry only 10 miles distant. A fast track flexible solution requiring the minimum of ground works.

- No Deep Pits
- No Underground Hoppers
- No Expensive Civil Works
- Flexibility of Location
- One Piece Integrated Machine
- Receives Direct from Trucks
- Receives Direct from Shovels
- Buffer Holding Capacity
- Fast Truck Discharge
- Controlled Rate Feeding
- Handles Dry and Dusty Materials
- Reduced Dust Generation
- Handles Wet and Sticky Materials
- No Risk of Bridging or Blockage
- Reduced Energy Consumption
- Easy Maintenance Access
- Easy Housekeeping Access
- Reliable in Service
- Proven References Worldwide



In this Cement Grinding Plant located in the London Docklands two Samson™ Material Feeders intake Cement Clinker plus Gypsum

An Economical Solution

As illustrated, a conventional underground truck tipping hopper with deep pit and feeder discharging to an inclined belt conveyor to raise the material out of the pit and onto the associated process plant.

It requires permanent and expensive civil works and cannot be relocated to accommodate plant development.

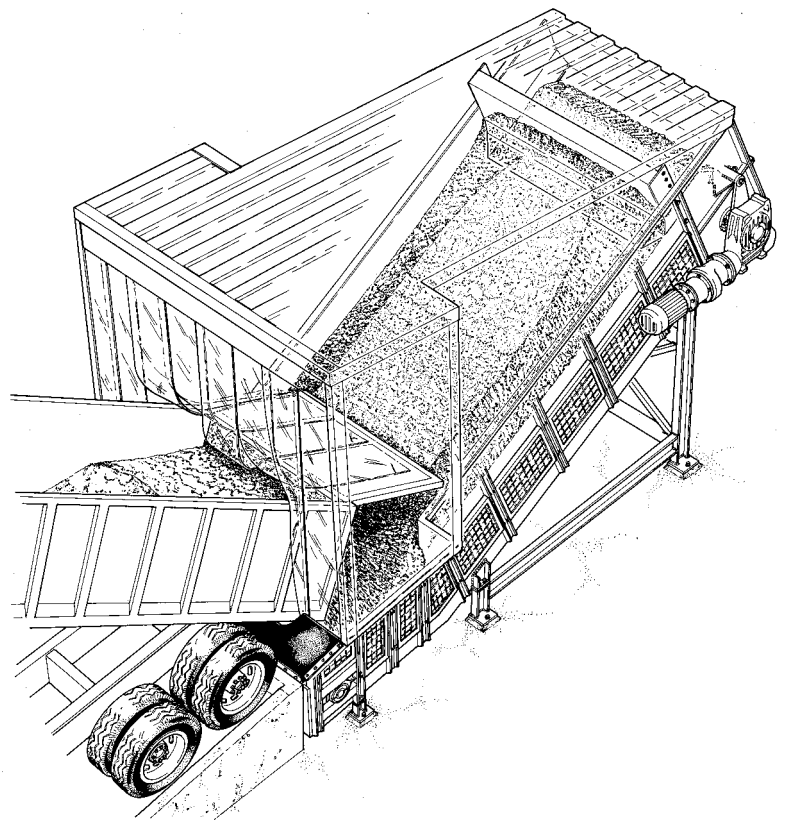
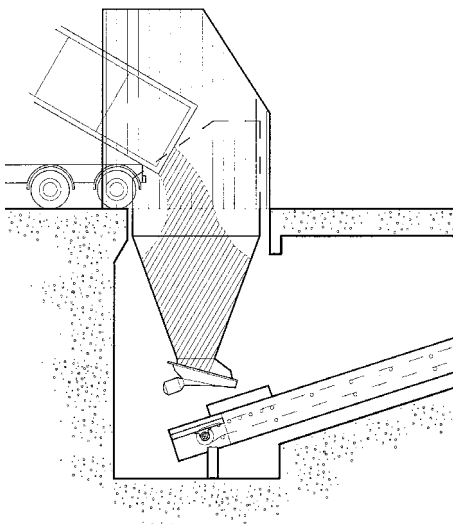

The Samson™ Bulk Material Receiving Unit Truck Dump Station



The wide Apron-Belt design permits a very low loading height which allows the trucks to discharge direct to the entry section with only a small access ramp.

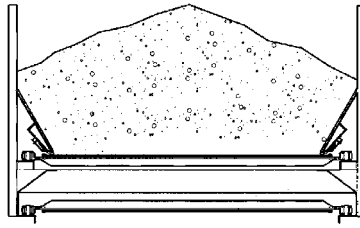

Wide belt design eliminates bridging



The wide Apron-Belt design combines the strength of a Steel Apron Feeder with the cleanliness of a Belt Feeder. Since the material depth is less than the belt width, the bridging and blockages associated with conventional tapered hoppers is completely eliminated guaranteeing reliable discharge.

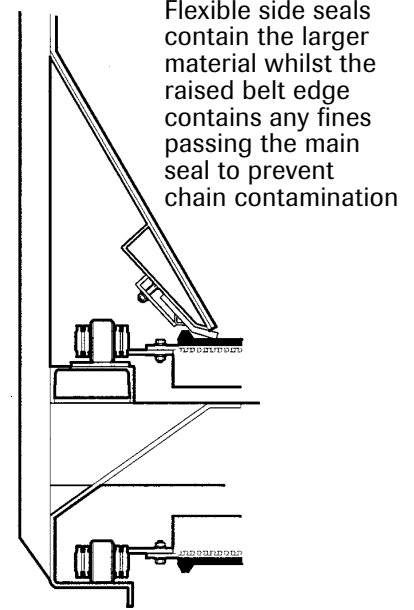

Flexible side seals contain the larger material whilst the raised belt edge contains any fines passing the main seal to prevent chain contamination

Highly developed over many years the Samson™ Material Feeder side seal contains the material within the body preventing spillage.

Construction Concept

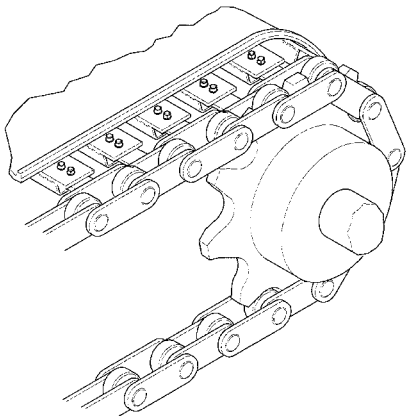

Trapezoidal shaped apron bars at every chain pitch provide maximum support and allow minimum sprocket diameter.



Flexible side seal with outer belt ledge



External chains outside the material flow



Steel Apron Bars support the load



Load carried on the chain rollers

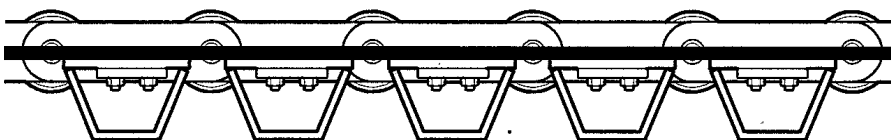

Conveyor belt aligned with the chain pin centre and rivetted to the Steel Apron Bars



Broken Glass is received by the Samson™ Material Feeder at a Recycling Operation

Operational Concept

Material is drawn from the tipping truck into the Samson™ Material Feeder body by the forward moving apron-belt conveyor. The operating concept can be divided into three stages as illustrated.

Stage A

The first truck arrives and discharges its material on to the forward moving Samson™ Material Feeder apron-belt. The belt moves forward, so the material is drawn from the truck body.

Stage B

When the truck is empty it departs the Samson™ Material Feeder and the material contained within the unit is continually discharged to the following conveyor system. The material moves forward and the entry section is exposed.

Stage C

After the first truck has departed, the following truck reverses into position. During this time period the forward moving apron-belt has exposed the entry section ready to accept the next truck contents.

And so it goes on...

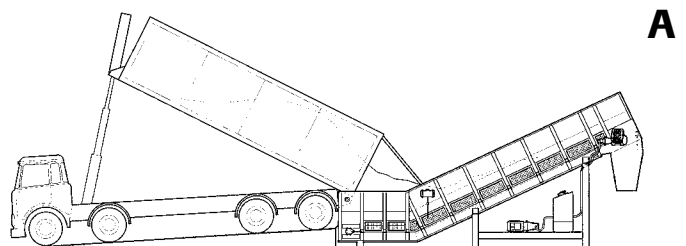

Material is drawn into the empty Samson™ Material Feeder body by the forward moving Apron-Belt

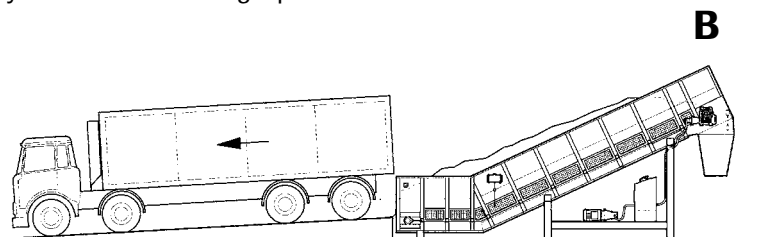

The complete truck contents transferred to the Samson™ Material Feeder body

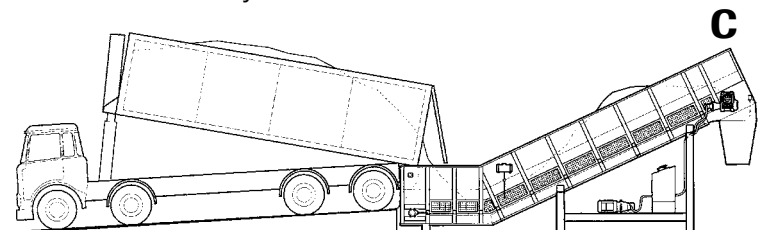

During the truck manoeuvring cycle the Samson™ Material Feeder entry empties ready to accept the next load



Material stored within the Samson™ Material Feeder body may be at various load levels along the length of the unit

Discharge Rate Control



Levelling blade controls the material bed depth at the discharge

As material is transferred from the truck or shovel to the Samson™ Material Feeder the load level varies from zero to 100 % along the machine length.

Since the output rate is proportional to the material bed depth and belt speed, it is necessary to regulate the bed depth such that the output rate may be controlled by varying only the belt speed.

The levelling blade solution maintains a constant bed depth at the discharge by cutting the peaks into the troughs and so enables the final output rate to be closely regulated.

For extremely cohesive materials the rotating teaser shown right performs the same task by cutting the flow into manageable pieces.

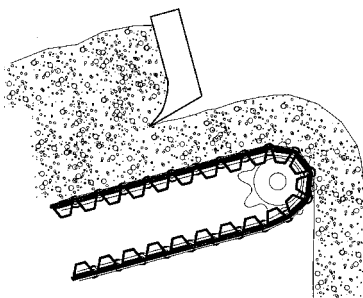

Rotating teaser provides a closely controlled discharge rate handling wet clay



The Samson™ Material Feeder with deflected chassis and parallel entry (width 3.0 m) receives broken glass from both tipping trucks and shovels

Body and Entry Designs

The Samson™ Material Feeder Deflected Chassis design provides a near horizontal loading section to receive material from tipping trucks. This maximises the entry volume and eliminate any risk of the truck tailgate fouling the apron-belt.

For use only with Shovels the Straight Chassis design is adequate to maintain the holding volume.

For operation with trucks the access ramp height directly controls the entry volume and therefore the time required to discharge the truck.

Illustration A shows a standard ramp giving a reasonable entry capacity of say 10 tons. Illustration B shows a raised ramp height giving an increased entry volume to reduce the truck tipping time and increase the overall average handling rate.

For operation with multiple truck designs, the Universal Truck Entry provides total flexibility.



The Samson™ Material Feeder with Straight Chassis and Flared Entry (width 4.5 m) receives sandy clay from shovels

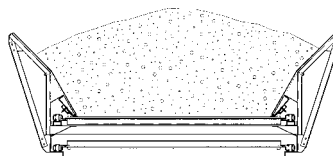

Flare entry width from 4.0 to 6.0 m.

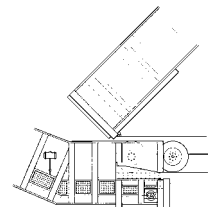

Universal Truck entry for all truck types

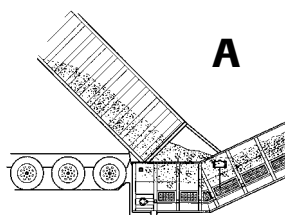

Standard ramp

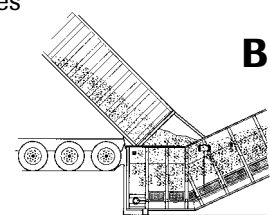

Raised ramp for greater entry volume



The massive Samson™ Material Feeder MF16xxx receives Gabbros Rock from Shovels for barge loading at 1,000 t.p.h.

Samson™ Material Feeder Construction

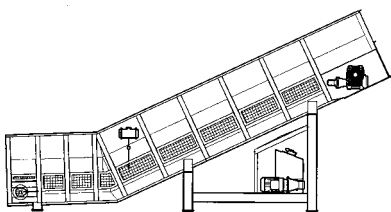

Samson™ MF03xxx

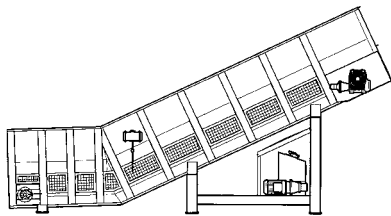

Samson™ MF04xxx

The Samson™ Material Feeder construction expands in strength as the chain specification increases

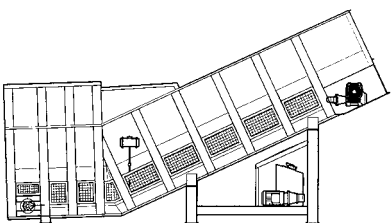

Samson™ MF08xxx

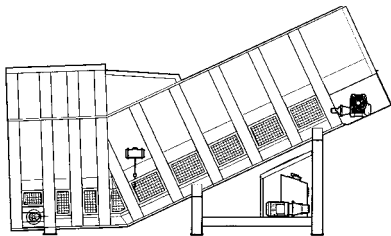

Samson™ MF16xxx

The Samson™ Material Feeder is available in five basic design ranges each signified by the chain tension rating known as.

Samson™ MF03xxx for light materials and low duty applications.

Samson™ MF04xxx with its short pitch chain design ideal for medium duty mobile applications where the lowest entry height is required.

Samson™ MF05xxx Super for medium duty continuous process applications typically handling fuels, crushed stone, clinker and similar graded materials.

Samson™ MF08xxx for continuous duty applications handling heavier mineral ores and where continuous availability is mandatory.

Samson™ MF16xxx for extreme duty applications including ROM material sizes and for the most arduous operating conditions.



The Samson™ Material Feeder with Deflected Chassis and Full Enclosure including Dust Filter receives Cement Clinker

Dust and Fume Control

The Samson™ Material Feeder is the ideal solution for the intake of dry and dusty materials where dust pollution is a real hazard.

Material free fall is nearly zero and the bulk of the truck contents is drawn into the body in a controlled stream which eliminates particulate separation and therefore virtually eradicating dust pollution at source.

Only when handling the dusties materials (Cement Clinker for example) is it necessary to provide dust extraction and then only a relatively small air volume is required. Typically only 25% of the rate required for extraction on conventional deep hoppers thus saving not only on capital cost but also on long term operational costs.



Flow into the Samson™ Material Feeder in a controlled stream

With a conventional underground hopper the material falls freely allowing particulate separation and generating high velocity displaced air.

The displaced air ejects the dust particles from the hopper at high speed causing extreme fugitive dust pollution with both environmental and health and safety implications.

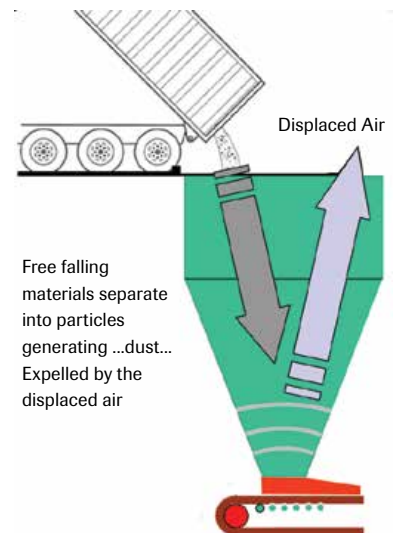

Conventional Underground Hopper



Resultant dust pollution



The Samson™ Material Feeder enclosure integrated to a complete coal preparation plant handling ROM material direct from the adjacent open cast mine

Enclosures Systems



Enclosure with fume extraction for odious materials



Flexible PVC sheet partial enclosure



Enclosure with extended flared entry for large Mining Dump Trucks



Full enclosure with flexible entry curtain but without dust extraction



Full enclosure with ducted dust extraction

Fixed enclosures clad in Profiled Steel sheeting over a fabricated steel frame made integral to the body of the Samson™ Material Feeder eliminating the need for additional or separate buildings... less cost... greater flexibility...

The enclosure may be supplied complete as flat-packed components for site assembly or may be manufactured locally with an engineering only package by SAMSON Materials Handling.



Samson™ Material Feeder with teaser discharges to an Inclined belt conveyor



Synthetic Gypsum Intake to Board Plant



Synthetic Gypsum discharged to horizontal belt conveyor

Discharge Interface

The parallel Head Chute eliminates risk of bridging and blockage when handling cohesive materials and it is always the preferred solution where the plant arrangement permits.

Where the ongoing conveyor is in-line or at an angle to the Samson™ Material Feeder, the centralising chute is the only option but usually this solution is less compact and requires an increased discharge height.



The Samson™ Material Feeder with a Centralising Head Chute discharges to a conveyor positioned in-line

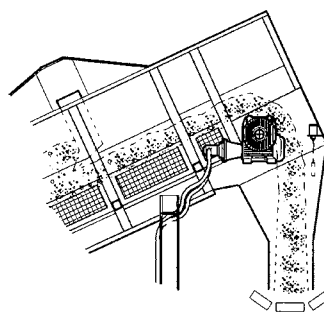

Parallel Head Chute for 90 degree Transfer

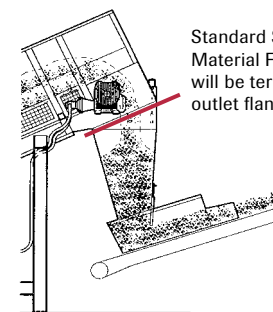

Standard Samson™ Material Feeder body will be terminated to an outlet flange at this level

Centralising Head Chute



Vibro-Feeder controlling feed rate to a Steep Angle Belt Conveyor



Single Screw Feeder provides metered output to a Bucket Elevator



Kleen-Line Belt Feeder transfer to Bucket Elevator

Feeder Options



Twin Screws meter output to progressive cavity pump

For closely controlled discharge rate down to a few cubic metres per hour a suitable feeder device at the Samson™ Material Feeder discharge is required.

Using the head chute as a small buffer hopper the output of the Samson™ Material Feeder is regulated using high a level detector to stop/start the drive and maintain a constant level in the head chute.

Generally not used with a Levelling Blade except in special conditions.



Vibro-Feeder with reject grill to remove over size material



Vibratory Feeder provides regulated output to an inclined belt conveyor



Four Samson™ Material Feeders provide an Alternative Fuel Intake facility to a major Power Plant

Alternative Fuels

To satisfy sustainability obligations major energy users such as Power Utilities and Cement Plants utilise renewable resources such as Wood Chip and other wastes, by-products and co-products to offset their Carbon Footprint.

The Samson™ Material Feeder is the ideal intake facility for such operations being able to handle most dry bulk solids with the added bonus of simplified installation, reduced project and operating costs and offering flexibility in location or possible relocation.



Wood Chip Intake for a Brewery Steam Boiler



Intake from high capacity Live Floor Trailers



The Wide Apron-Belt Samson™ Material Feeder concept is ideal for difficult materials



Samson™ Material Feeder MF16xxx with Tandem Drives using two Helical/Bevel Speed Reducers mounted one each side of the extended head shaft

Drive Systems



High efficiency Helical/Bevel main reduction gear with helical primary



Direct Coupled Hydraulic Motor Drive with local or remote hydraulic power unit allowing the electric motor and control equipment to be positioned clear of the feeder in a more accessible location.

Stand alone Samson™ Material Feeders are generally supplied with

direct coupled electric motor drives with helical/bevel speed reducer mounted direct to the extended head shaft. For special applications tandem gears may be supplied (as shown above) and also hydraulic drives are available. ATEX certification supplied where required.

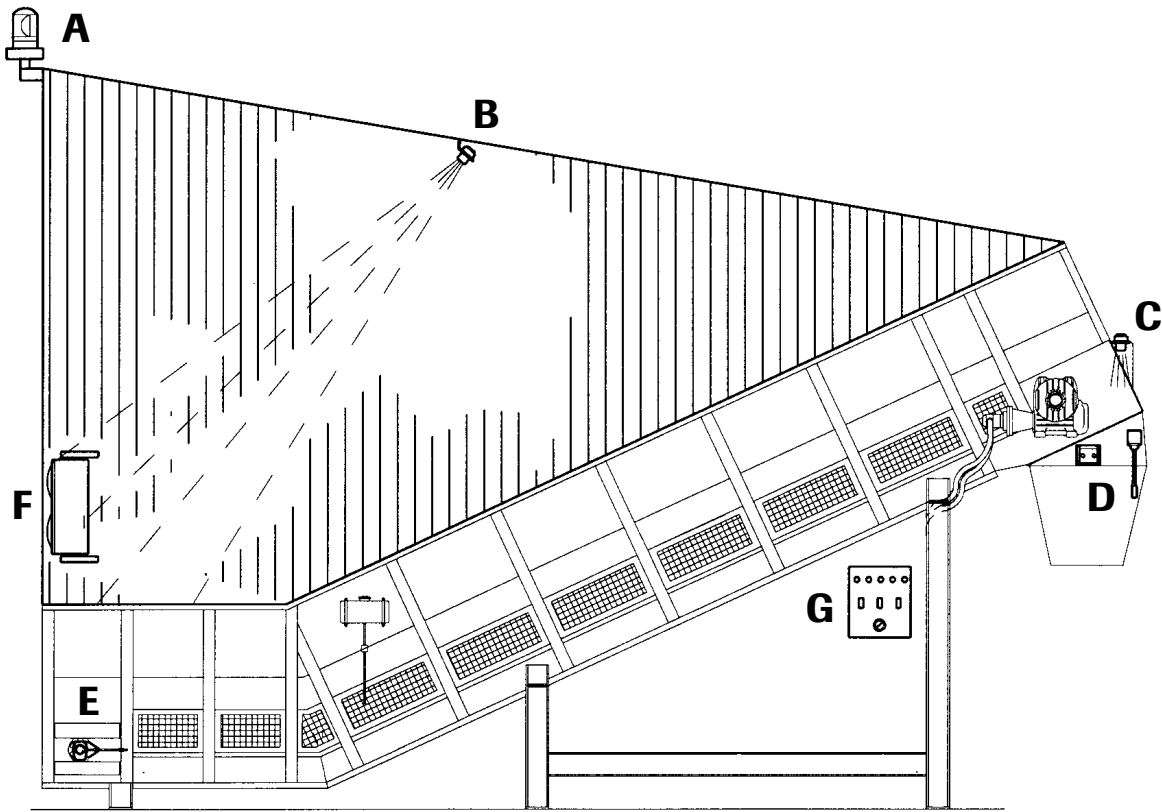

Instrumentation

For the safe operation and protection of the Samson™ Material Feeder various items of field instrumentation are available:

- A** Rotating Warning Beacon linked to a drive torque monitoring system to warn of impending overload and indicate to the operator to cease filling.
- B** Ultrasonic Detector to signal the presence of a vehicle at the entry and initiate a controlled startup sequence for the Samson™ Material Feeder and the ongoing plant.

- C** When the head chute forms a buffer hopper for an ongoing feeder this Level Detector is linked to the drive control to start the Samson™ Material Feeder on low level and stop on high level, see the diagram or the right.
- D** Blocked Chute detector arranged to stop the drive if the head chute is over filled or blocked with material.
- E** Tail shaft Rotation Sensor to inhibit the drive system in the event rotation is lost in normal operation.

- F** Traffic Lamp linked to the on-going process control to signal either the machine readiness or the grade or type of material required.
- G** Local control cabinet plus safety stop system.

Instruments are generally supplied loose but with mounting brackets to fix to the Samson™ Material Feeder or Chutes.

Chute Level Detection for use with an auxiliary feeder or when the ongoing conveyor acts as an extractor to control the feed rate.



Twin Samsons™ Material Feeder with Traffic Management

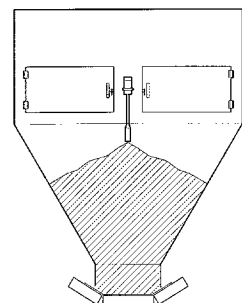
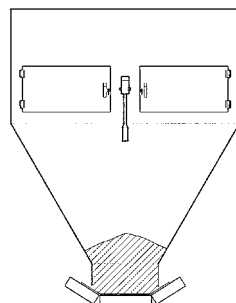

Samson™ Material Feeder starts on low level stops on high level



Local Cabinet with Motor Control Gear

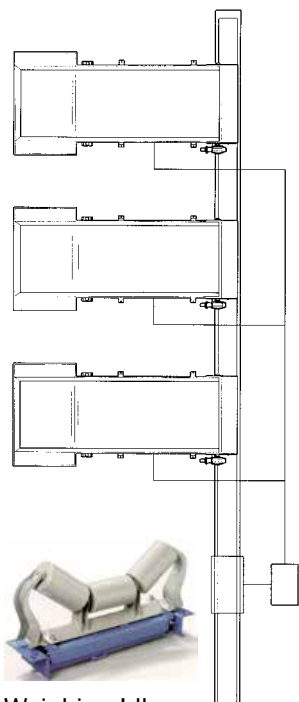

Weighing Idler



Inverter Speed Control Modules located local to the Samson™ Material Feeder but linked to a remote control room

Controls

Variable Output Rate

To control the output rate of the Samson™ Material Feeder using the Levelling Blade system it is necessary to provide variable speed for the belt drive.

For mechanical drives an inverter is required to control the motor speed and therefore the belt speed. For a fixed levelling blade height the volumetric output rate is proportional to the belt speed.

For output rate control by mass the speed control may be linked to a belt weigher on the following conveyor.

Interfaces

Invariably the Samson™ Material Feeder will be linked to a plant control system for sequencing with other equipment.

The Samson™ Material Feeder may be supplied with a local PLC plus necessary communication protocol compatible with the main plant control systems.

Blending Systems

When several different materials must be blended onto a common collecting conveyor multiple Samson™ Material Feeders, one for each material type, may be linked to a central controller and arranged to discharge a set blend ratio as a proportion of the total output as measured by a downstream belt weigh idler.

Control units are supplied loose for site installation either complete with all necessary motor control and logic gear or as a local control station only linked to an existing central motor control centre (MCC) perhaps located some distance from the equipment.



Samson™ Material Feeder plus Twin Shaft Rotary Sizer receives as-mined Limestone from dump trucks and provides a manageable lump size for onward conveying

Sizing and Screening

The Samson™ Material Feeder may be supplied complete with integral rotary crusher or screening equipment to size the raw material before onward conveying, either as a package or engineered to suit, free issue equipment.



Samson™ Material Feeder supplied with Vibrating Screen to remove oversize material before onward conveying

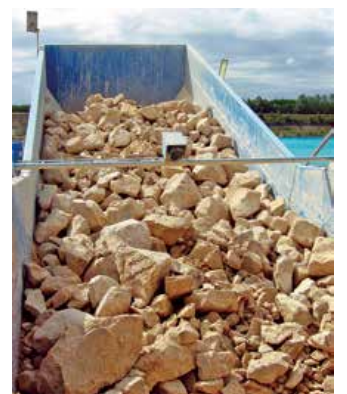

As-mined Limestone minus 800 mm



The Samson™ Material Feeder MF08xxx Series provides 100 cubic metres of live storage for Alternative Fuels in a Cement Plant

Live Storage Solutions



Extended Inclined Section for increased storage or discharge height



For handling difficult materials that are liable to bridge and block in conventional silos the Samson™ Material Feeder offers the ideal solution for live storage with holding capacities up to around 200 tons.

Illustrated is the conventional Samson™ Material Feeder design with horizontal loading section and inclined discharge. With this arrangement the storage volume is generally limited by the increased chain tension required to raise the load.

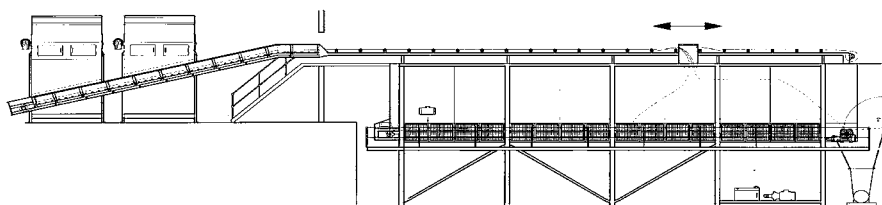

The Samson™ Material Feeder Horizontal Storage Bunker with Overhead Conveyor and Plough Discharger



Specialised application for the storage of Sewage Sludge including twin Samson™ Material Feeders each with belt conveyor transfer to two horizontal storage units within the building, both to store and discharge on demand.



The Side Loading Samson™ Material Feeder receives Cement Clinker for import directly to an existing conveyor installation

Side Loading and Drive over Tipping

In confined spaces the Side Loading solution may provide an economical alternative allowing a simplified plant layout with reduced transfer points and minimum disruption to the process operation during the new equipment installation.

Side loading is particularly suited to drive-over-tip applications where the Samson™ Material Feeder may be mounted below floor level or supplied with a suitable ramp, thus allowing the trucks to drive over the entry section, tip and continue in the same direction, as illustrated below, the Samson™ Material Feeder is below the floor level.



Truck passes over the closed doors



Special truck for wet and sticky Nickel Tailings



Truck discharges through open doors

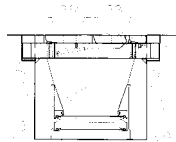

Steep Samson™ Material Feeder Sides Plates eliminate bridging

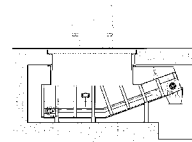

Samson™ Material Feeder beneath opening doors above

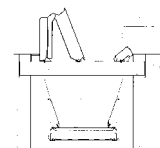

Stop Raises and doors open automatically



Twin Samson™ Side Tip Feeders with Vertical Elevators to Dome Storage



Discharge facility for Hopper Bottom Railcars receives coal for a Cement Plant including a Samson™ Material Feeder with 80 tons holding capacity

Samson™ Material Feeder - Under Rail or Road

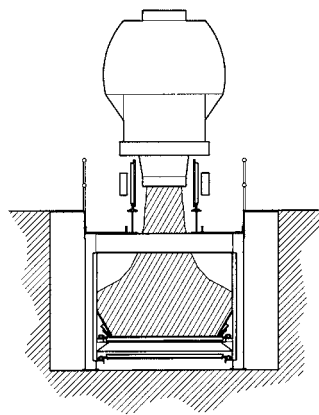

The Samson™ Material Feeder solution for Railcar discharge may be implemented in a shallow pit, typically with depth only 4.0 metres, ideally suited in port area with high ground water level or where working on hard rock increases the cost of the excavation. A conventional tapered hopper could require as much as 14 metres of excavation to obtain the necessary hopper angle for reliable material flow handling such as industrial coals etc.

With a shallow pit, the material free fall is minimised and, since the Apron-Belt of the Samson™ Material Feeder is wider than the typical railcar, the material flows outward reducing the velocity of the displaced air and thereby reducing dust generation.

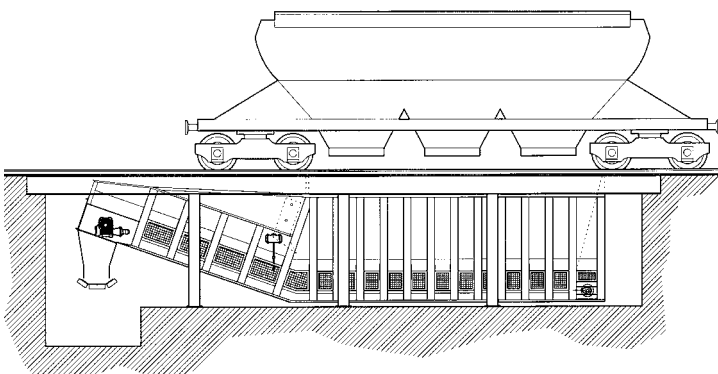

With the deflected chassis design the raised discharge provides an ideal transfer to the following conveyor which, thanks to the shallow pit depth, may be of reduced length and therefore reduced energy input saving on capital and running costs.

The Wide Apron-Belt Samson™ Material Feeder concept permits a shallow excavation and economical installation



Twin Samson™ Material Feeders with Full Dust Control integrated to this Mobile Shiploader permits direct bulk export from truck to ship

Mobile Shiploader and Stacker with Integral Samson™ Material Feeders



Stormajor™ Boom Feeder with integrated Samson™ Material Feeder MF16xxx Series and Radial Stacking Boom for Barge Loading



Stormajor™ combines the benefits of a Samson™ Material Feeder with a Radial Stacking Boom mounted to a common mobile chassis

After Sales and Services

SAMSON Materials Handling Ltd. strive to deliver the highest standards of customer support and after sales service worldwide with the collaboration of the local AUMUND Group daughter companies and representative offices and including:

- Application advice
- Port or Plant Infrastructure Survey
- Performance and Selection Criteria
- Operational Guidance
- Machine Selection and Specification
- Supervision of Site Assembly
- Commissioning
- Advice on Maintenance Programmes
- Rebuilding and Refurbishment
- Genuine Spare Parts
- Service Contracts

Our engineers are highly trained and experienced in the SAMSON Material Handling products and familiar with port operations and the demands of shipping schedules where equipment availability is critical to avoid demurrage costs.



THE AUMUND GROUP

GERMANY

AUMUND Fördertechnik GmbH

Saalhoffer Str. 17
47495 Rheinberg
Phone: +49 - 2843 - 72 0
Fax: +49 - 2843 - 6 02 70
e-mail: aumund@aumund.de
www.aumund.com

Aumund Logistic GmbH

Saalhoffer Str. 17
47495 Rheinberg
Phone: +49 - 2843 - 72 0
Fax: +49 - 2843 - 7 24 73
e-mail: logistic@aumund.de
www.aumund.com

SCHADE Lagertechnik GmbH

Dorstener Straße 360
44653 Herne
Phone: +49 - 2325 - 58 74 0
Fax: +49 - 2325 - 58 74 74
e-mail:
info@schade-lagertechnik.de
www.schade-lagertechnik.com

GREAT BRITAIN

SAMSON Materials Handling Ltd.

Gemini House Cambridgeshire
Business Park, 1 Bartholomew's Walk
Ely, Cambridgeshire CB7 4EA
Phone: +44 - 1353 - 665 001
Fax: +44 - 1353 - 666 734
e-mail: sales@samson-mh.com
www.samson-mh.com

INDIA

AUMUND Engineering Private Ltd.

2nd Floor, Lakshmi Neela Rite Choice
Chambers · 9, Bazulla Road,
T. Nagar Chennai - 600 017
Phone: +91 - 44 - 4393 63 00
Fax: +91 - 44 - 2815 60 46
e-mail: aumund@vsnl.com

HONG KONG SAR

AUMUND Asia (H.K.) Limited

Unit 3B & 5, 30/F.
148 Electric Road
North Point
Hong Kong
Phone: +852 - 3695 - 43 33
Fax: +852 - 3695 - 43 11
e-mail: info@aumund-asia.com

DUBAI U.A.E.

AUMUND Fördertechnik GmbH Representative Office

P.O. Box 35291
Dubai, UAE
Phone: +971 - 4 - 2823762
e-mail: catalina@aumund.com

THE NETHERLANDS

AUMUND Holding B.V.

Wilhelminapark 40
5911 EE Venlo
Phone: +31 - 77 - 320 01 11
Fax: +31 - 77 - 320 07 28
e-mail: info@aumund-holding.nl

SWITZERLAND

AUMUND AG

Arther Str. 3
6301 Zug
Phone: +41 - 41 - 710 10 82
Fax: +41 - 41 - 710 42 02
e-mail: info@aumund.ch

RUSSIA

AUMUND Representative Office

German-Russian House, Office 44
ul. Malaja Pirogovskaja 5
119435 Moscow / Russia
Phone: +7 - 495 - 287 90 02
Fax: +7 - 495 - 287 90 06
e-mail: info@aumund.ru

FRANCE

AUMUND France S.A.R.L.

43, rue de Trévisse · F 75009 Paris
Phone: +33 - 1 - 42 46 72 72
Fax: +33 - 1 - 42 46 72 74
e-mail: aumund@aumund.fr

BRAZIL

AUMUND Ltda.

Avenida Eng. Luis Carlos Berrini
716 - 4.andar - conj. 41
04571-000 - São Paulo / SP
Phone: +55 - 11 - 3059 0160
Fax: +55 - 11 - 3059 0161
e-mail: aumund@aumund.com.br

USA

AUMUND Corporation

1825 Barrett Lakes Boulevard
Barrett Lakes Center II
Suite 520
Kennesaw, GA 30144
Phone: +1 - 770 - 226 - 95 78
Fax: +1 - 770 - 953 - 48 44
e-mail: sales@aumundusa.com

P.R. CHINA

AUMUND Machinery Trading (Beijing) Co. Ltd.

Rm. 7-8, 22-F, East Ocean Centre
No. 24 Jianguomenwai Avenue
Chaoyang District
Beijing 100004
Phone: +86 - 10 - 65 15 58 13 / 14
Fax: +86 - 10 - 65 15 58 15
e-mail: aumund@aumund.cn



SAMSON office building Ely, U.K.

AUMUND GROUP Headquarters in Rheinberg, Germany

SAMSON

AUMUNDGROUP

Dedicated to providing the most comprehensive range of mobile solutions for bulk materials handling in Ports and Terminals, Mining, Environmental, Cement, Foodstuffs, Agriculture and Power.

Built around the unique concept of the Samson™ Material Feeder, SAMSON Materials Handling offer flexibility, reliability, quality, and industry leading performance from truck intake right through to mobile stacking and ship loading solution.

SAMSON Materials Handling Ltd.

Gemini House, Cambridgeshire Business Park, 1 Bartholomew's Walk, Ely, Cambridgeshire CB7 4EA, England

Tel.: +44-1353-665001 • Fax: +44-1353-666734 • e-mail: sales@samson-mh.com

www.samson-mh.com