



## **Biomass Logistics**

Solutions from Forest  
to Ports and Power Plants

**SAMSON**  
AUMUND GROUP

## CONTENT

- 
- 3 From Forest to Consumer

---

  - 4 Logistics Chain

---

  - 5 Road Haulage

---

  - 6 Samson™ Material Feeder Road Intake

---

  - 7 Tipping Platforms

---

  - 8 Road Intake Stations

---

  - 9 Introducing Biomass

---

  - 10 Shipment by Barge

---

  - 11 Transfer and Transshipment

---

  - 12 Rail Haulage

---

  - 13 Hopper Wagon Discharge

---

  - 14 Flat Bottom Wagon Discharge

---

  - 15 Samson™ Box Feeder

---

  - 16 Mobile Shiploader

---

  - 17 Ship Trimming

---

  - 18 Truck to Ship Loading

---

  - 19 Integrated Shiploader Solutions

---

  - 20 Mobile Grab Hoppers

---

  - 21 Rail Mounted Grab Hoppers

---

  - 22 Local Resources

---

  - 23 After Sales and Services

## Biomass Handling for Flexible Solutions

Since the early 1980s SAMSON Materials Handling Ltd. have developed a range of materials handling solutions dedicated to the reliable intake, storage and export of general bulk cargoes including many unusual and cohesive materials such as Biomass Fuels.

Flexibility is at the core of our product concept; from truck intake, using the Samson™ Material Feeder, through to mobile stacking and ship loading solutions able to operate from existing berths.

Our goal is to deliver this flexibility without compromising performance, environmental standards, safety or reliability. Delivering the same performance as you would expect from a traditional fixed installation with the benefit of complete mobility.



High performance Mobile Shiploader operates on any berth and may be moved clear for other port operations



## From Forest to Consumer

Most Biomass fuels reaching modern dedicated or multi-fuel power plants originate in managed forests or from the residues of timber processes. They are generally broken into Wood Chip (coin sized pieces of wood) and often then dried and extruded into Wood Pellets.

Non-Fossil-Fuel obligations force electricity utilities to source power from sustainable resources, of which Wood Chip or Pellet is the most prolific, demanding efficient international logistics.



Longitudinal Storage with Portal Reclaimer by SCHADE



Circular Storage with Cantilever Reclaimer by SCHADE



Averdore Multi-Fuel Power Plant in Denmark

# Logistics Chain

After the chipping or pelletising process, the wood based fuel becomes a valuable carbon neutral resource, able to make a real contribution towards reducing the carbon footprint of Power and Combined Heat and Power (CHP) plants.

Unfortunately, the source is often far removed from the demand requiring efficient logistics at each stage in between.

- Haulage from the logging operation to the saw mill or process plant
- Chipping and Pelletising waste materials to form a sustainable economic fuel
- Deepsea shipment from producer to power utility or CHP plant through bulk import terminal
- Transfer by road or rail from the import terminal to the consumer
- Truck haulage of locally available biomass from farm to dedicated power plant





## Road Haulage

Walking Floor Trucks have a live bottom in the trailer floor, comprising reciprocating bars that move back and forth beneath the load and with a moving bulkhead the contents are discharged.

Worldwide there are a vast range of truck styles all dedicated to their specific markets and local customs. Standard end tipping solutions are still by far the most popular but in some markets the side dumper is also used.

For the haulage of wood chip in developed markets, the dedicated through dumper trailer as shown above hauling for Sunbury, gives the maximum payload within established regulations.

These trucks are raised on a tipping platform as illustrated opposite and the wood chip flows through the two bodies exiting via a hinged rear door into the intake system at the processor or power utility.



Self Discharging Walking Floor High-Cube Trailer



Dedicated Wood Chip Hauler with High-Cube Twin Trailers



## Samson™ Material Feeder Road Intake

Wood Chip intake from trucks can be a tricky business. Wood Chip tends to block and blind, does not flow easily through inclined chutes and cannot be handled reliably in standard tapered hoppers. In this situation the wide belt Samson™ Material Feeder is ideal.

Thanks to the Wide Apron Belt design the carrying surface is wide relative to the material depth delivering reliable storage and discharge.

Material is drawn into the Samson™ Material Feeder body from the tipping truck in a controlled stream allowing fast truck turnaround, and with minimum free fall, dust generation is mitigated at source requiring much reduced extraction to eliminate fugitive dust nuisance.





## Tipping Platforms



High-Cube trucks are often designed specifically for hauling wood chip and to maximise the volume, they do not use traditional tipping or moving floor systems. These trucks are discharged on a tipping platform shown here integrated to a Samson™ Material Feeder discharging to conveyor.

A range of intake combinations are possible including drive-over tip and high volume side tip with or without tipping platform. Drive over designs include an opening door system to reveal the Samson™ Material Feeder below unobstructed to eliminate any risk of blockage or blinding on grills often used in this configuration.



## Road Intake Stations

Shown above at the Electrobel power plant in Poland, four Samson™ Material Feeders receive various types of Agri-Biomass including Wood Chip to augment the coal stream and reduce the utilities carbon footprint.



Wide Apron-Belt



Heineken Brewery Biomass Intake



Discharge from Samson™ Material Feeder to Vertical Bucket Elevator

These projects are typical of new CHP plant designed to intake Biomass to an established power utility, a historic brewery in Manchester (England) and to the new Biomass boiler fuel intake for the Tullis Russell paper plant in Scotland replacing the existing Samson™ Material Feeder coal intake installed back in 1987.

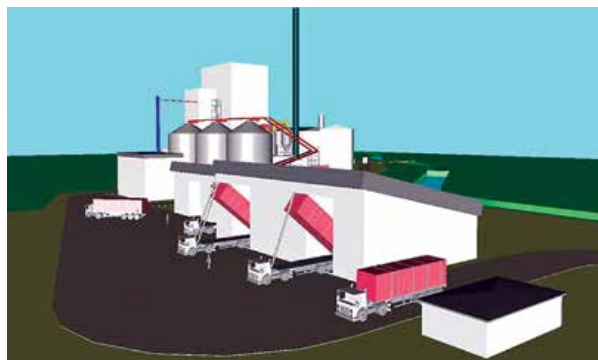

Tullis Russell Paper Plant



Original Coal Intake





## Introducing Biomass to Existing Plant



By eliminating deep pits and underground hoppers the Samson™ Material Feeder provides a flexible solution for the introduction of Biomass to existing coal fired plant as shown here at Kingsnorth in the UK handling Biomass and at an RWE plant in Germany handling Meat and Bone Meal.



Transfer by Screw Feeder and Conveyor



Weigh Belt Feeder gives Close Output Control



## Wood Chip Shipment by Barge

Barge traffic on inland waterways offers the most economical and sustainable solution for the large scale movement of Wood Chip using high capacity, towed or motorised barges or Coasters for delivery to the power plant or port for transshipment to deep sea vessels.

The Stormajor™ Boom Feeder combines the benefits of the Samson™ Material Feeder surface feeder with a radial loading boom onto a single autonomous chassis and so is suitable for either barge loading or stacking.

Using the cantilevered outloading boom, the Stormajor™ Boom Feeder may reach out to barges moored in deep water off the river bank eliminating the need for expensive dredging or permanent port facilities, only a simple hard standing is required.



Stormajor™ Boom Feeder exporting Wood Pellets at the Port of Frederica in Denmark

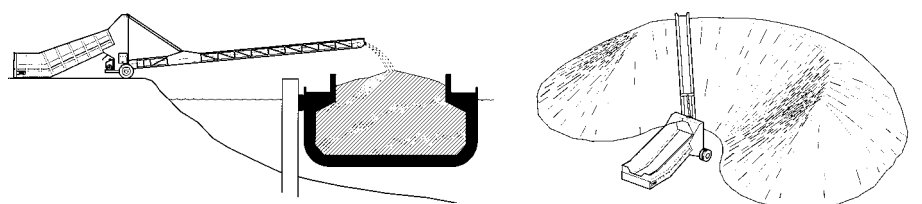



## Import, Transfer and Transshipment



Stormmajor™ Boom Feeder introducing fuels to an existing conveyor belt at Hong Kong Electric



Stormmajor™ Boom Feeder a flexible solution for Rail Wagon Loading



Stormmajor™ Boom Feeder is a universal tool suitable for Stockpiling, Barge Loading and Rail Wagon Loading and for the import of Wood Pellets from small coaster when combined with a grab hopper discharging to existing conveyor systems or storage facilities.

The Stormmajor™ Boom Feeder radial cantilevered stacking boom is ideal for stockpiling and also suitable for handling a wide range of materials for maximum flexibility.

The Stormmajor™ Boom Feeder is available with a range of ancillary equipment such as trimming chutes for loading rail wagon or barge, powered travel for easy movement on the quay or stockyard, on-board diesel power for complete autonomy, requiring no shore power or dedicated infrastructure.

A truly flexible intake, import or export solution, the Stormmajor™ Boom Feeder is a Stacker, a Barge Loader, a Rail Wagon Loader and a Mobile Transfer Conveyor and may move easily between jobs.



## Wood Chip Haulage by Rail

Where the producer and user are rail connected, haulage by high volumetric capacity rail wagons is the ideal solution for inland movement. Both Unit Trains with Gondola style wagons and hopper wagons are used depending on the method of discharge.

Special high cubic capacity hopper wagons with multiple wide opening clam-shell style discharge doors are required for fast emptying without risk of bridging or blockage at the outlet. This demands an Under Rail Feeder able to receive, store and feed the material to the onward conveying systems.



Unit Train with Gondola Wagons suitable for discharge by Wagon Tippler



## Hopper Wagon Discharge

The Samson™ Material Feeder - Under Rail offers substantial advantages by reducing the required pit depth and, thanks to the Samson™ Wide Belt design, eliminates any risk of blockage or blinding making the installation more reliable and economical whilst reducing dust generation.

Shallow Pit design with Raised Discharge reduces construction costs, particularly in ports where high ground water requires special pit construction; reduced civil works, easy access.

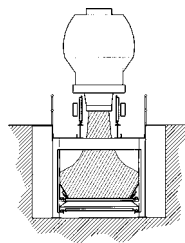

Shallow Pit design with limited free fall height reduces dust and minimises pellet degradation

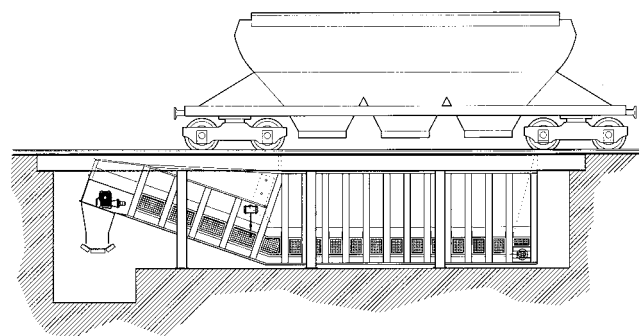

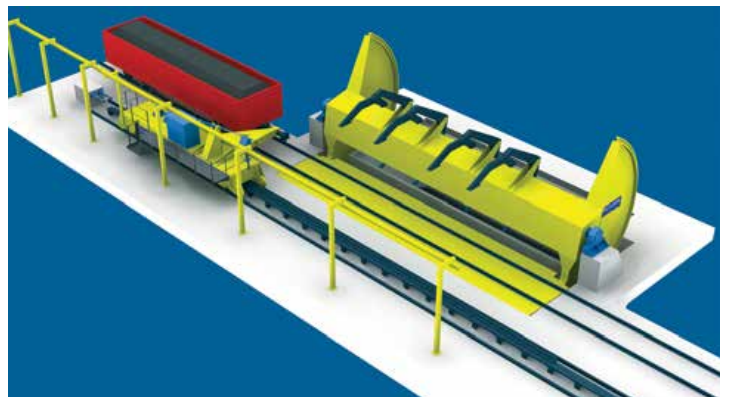
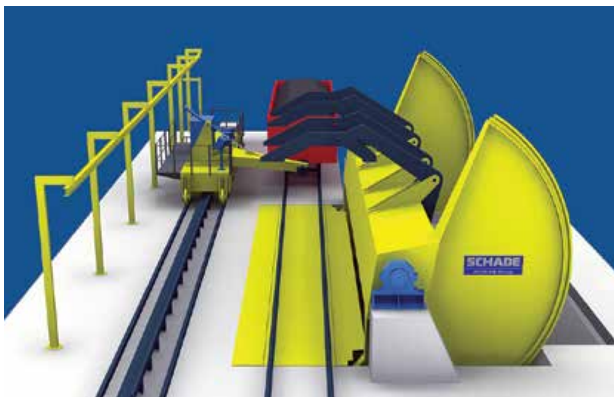

## Flat Bottom Wagon Discharge

For open top flat bottom rail wagons the Rotary Wagon Tippler by SCHADE is an elegant solution allowing the wagon to be inverted and discharged to a hopper and feeder below. The "O" Frame design shown above will handle unit trains and random wagons.

Pivot Frame Tipplers raise the wagon and discharge the contents to a Samson™ style Box Feeder positioned beside the rail.

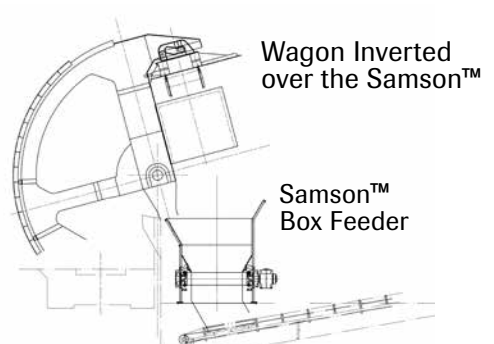
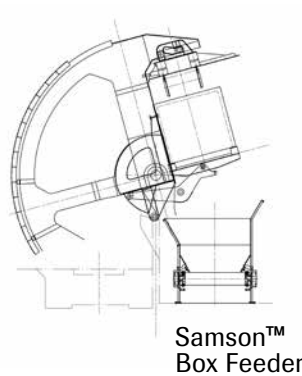
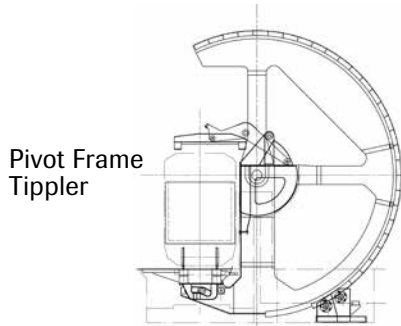



## Samson™ Box Feeder

The Samson™ Box Feeder concept is similar to the Under Rail application but in this case the unit is installed at ground level and the Pivot Frame Wagon Tippler discharges each uncoupled wagon to the feeder in turn. Surface installation is economical and flexible



Discharge Direct from Samson™ Box Feeder to Mobile Conveyor

Surface installation with minimum civil works is a considerable benefit. In this case the Samson™ Box Feeder with raised discharge delivers the material easily to a Loadmaster “E” Series Mobile Conveyor for loading direct to road trucks for the final delivery to the power plant. With skid mounted and mobile equipment comes complete flexibility in location and easy relocation.



Minimum Civil Works and simplified installation



## Mobile Shiploader with Link Conveyor

For the Port of Panama (Florida, USA) Wood Chip is exported in Handymax vessels from a local on-port storage facility. A telescopic Link Conveyor with radial travel provides a flexible connection between the fixed and mobile conveyor system.

Combining a Mobile Conveyor and Shiploader gives the flexibility to use dedicated storage just off the berth whilst retaining the flexibility to easily clear the berth for other operations.

For ship trimming this machine is supplied with powered in-line, parallel and radial movements combined with a Cascade style dust controlled trimming chute and integral filters.







Rotating Trilling Chute for accurate material placement

## Effective Hold Trimming



Telescopic Cascade Trimming Chute comprising a stack of inclined cones control the material flow velocity therefore prevent particulate separation controlling dust generation at the source

Combined with radial travel and multiple Link Conveyors even the largest vessels may be effectively loaded and trimmed from a fixed conveyor system terminating just off the berth as illustrated below at the Port of Eastport in the USA exporting Wood Chip for the EU market.

Vessels to Panamax size may be economically loaded with mobile equipment working from an existing multi-purpose berth requiring no special foundations, civil works or even power supply.

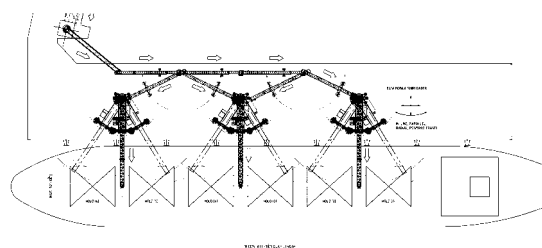

A single Shiploader may be positioned to load any combination of holds using the mobile Link Conveyors to transfer Wood Chip from the fixed conveyor located off the berth



## Truck to Ship

By integrating two Samson™ Material Feeders to a common outloading boom, the fully autonomous Shiploader may receive almost any bulk cargo including Wood Chip, Pellets or Grains direct from tipping trucks so eliminating the need for intermediate on-port storage.

Illustrated here, independent mobile Samson™ Material Feeders are used in pairs to load a single Shiploader boom allowing two trucks to be discharged simultaneously.

Both, the Samson™ Material Feeder and Shiploader units are tow travelled but provided with parallel movement to speed the relocation along the vessel for effective hold trimming.





## Integrated Professional Solutions



Where dust is not an issue, the Radial Jet-Slinger is an effective Ship Trimmer

By integrating two Samson™ Material Feeders to a common outloading boom including both in-line and parallel travel, the fully autonomous Shiploader may be easily moved along the vessel for trimming to save time and increasing the effective “Through the Ship” loading rate.

Shiploaders are offered with a range of trimming options, from simple rotating chutes as shown above through to Cascade or dust controlled chutes or Radial Jet-Slinger Trimmers to suit the project demands.



Twin Samson™ Material Feeders mounted to the Shiploader



Loading to Panamax size ships



Eco Hopper discharges direct to trucks for movement to inland storage

## Dust Controlled Bulk Import

The Eco Hopper receives material by grab from up to Cape Size vessels discharged by Mobile Harbour Crane. With the patented SAMSON dust extraction system and Flex-Flap one way material inlet valve, fugitive dust escape is kept under control.

The Eco Hopper may be either tow travelled or supplied with integral powered travel plus diesel genset for complete autonomy. As with the Mobile Shiploader the Eco Hopper may be moved off the berth when not required.





## Import Facility with Twin Eco Hoppers



Here, Rail Mounted Eco Hoppers are installed on a dedicated jetty for the import of bulk materials from geared small bulk carriers. The discharge from the Eco Hopper is conveyed inland by troughed belt conveyor and overhead Tripper Car to a flat storage facility on the port.

For dedicated river or canal berths an integrated scheme with on port storage offers maximum flexibility for the onward transportation of the Biomass from the port to the user either by road or rail freight.

In addition to Biomass, such facilities can also handle other dry bulk cargoes for maximum flexibility.

Rubber tyred Eco Hoppers may also be used with fixed conveyors and on-port storage where the berth must remain free between the discharge of bulk cargoes.



Trucks reverse into closed discharge hall



Chicken Litter loaded to Trucks at Local Farms

## Local Resources

EPR Thetford generate some 38.5 mW. of power from their plant in the rural east of England fuelled 100% on Biomass comprising mainly Chicken and Turkey litter collected in special enclosed trucks from the local farmers. A total of 450,000 tons is consumed each year.

Trucks reverse to the fuel intake hall where six Samson™ Material Feeder units accept the litter whilst providing a buffer holding capacity and a controlled discharge rate to the following disc screens which remove any tramp material. The screened material falls through to another set of six Samson™ Material Feeders which regulate the final discharge.

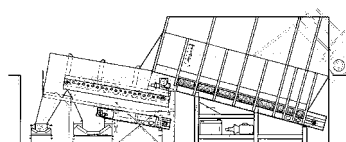

Samson™ Receiving Unit with Levelling Blade output control Disk Screen and Sub-Screen Feeder

# After Sales and Services

SAMSON Materials Handling Ltd. strive to deliver the highest standards of customer support and after sales service worldwide with the collaboration of the local AUMUND Group daughter companies and representative offices and including:

- Application advice
- Port or Plant Infrastructure Survey
- Performance and Selection Criteria
- Operational Guidance
- Machine Selection and Specification
- Supervision of Site Assembly
- Commissioning
- Advice on Maintenance Programmes
- Rebuilding and Refurbishment
- Genuine Spare Parts
- Service Contracts

Our engineers are highly trained and experienced in the SAMSON Materials Handling products and familiar with port operations and the demands of shipping schedules where equipment availability is critical to avoid demurrage costs.



## THE AUMUND GROUP

### GERMANY

#### AUMUND Fördertechnik GmbH

Saalhoffer Str. 17  
47495 Rheinberg  
Phone: +49 - 2843 - 72 0  
Fax: +49 - 2843 - 6 02 70  
e-mail: aumund@aumund.de  
www.aumund.com

#### Aumund Logistic GmbH

Saalhoffer Str. 17  
47495 Rheinberg  
Phone: +49 - 2843 - 72 0  
Fax: +49 - 2843 - 7 24 73  
e-mail: logistic@aumund.de  
www.aumund.com

#### SCHADE Lagertechnik GmbH

Dorstener Straße 360  
44653 Herne  
Phone: +49 - 2325 - 58 74 0  
Fax: +49 - 2325 - 58 74 74  
e-mail:  
info@schade-lagertechnik.de  
www.schade-lagertechnik.com

### GREAT BRITAIN

#### SAMSON Materials Handling Ltd.

Gemini House Cambridgeshire  
Business Park, 1 Bartholomew's Walk  
Ely, Cambridgeshire CB7 4EA  
Phone: +44 - 1353 - 665 001  
Fax: +44 - 1353 - 666 734  
e-mail: sales@samson-mh.com  
www.samson-mh.com

### INDIA

#### AUMUND Engineering Private Ltd.

2nd Floor, Lakshmi Neela Rite Choice  
Chambers - 9, Bazulla Road,  
T. Nagar Chennai - 600 017  
Phone: +91 - 44 - 4393 63 00  
Fax: +91 - 44 - 2815 60 46  
e-mail: aumund@vsnl.com

### HONG KONG SAR

#### AUMUND Asia (H.K.) Limited

Unit 3B & 5, 30/F.  
148 Electric Road  
North Point  
Hong Kong  
Phone: +852 - 3695 - 43 33  
Fax: +852 - 3695 - 43 11  
e-mail: info@aumund-asia.com

### DUBAI U.A.E.

#### AUMUND Fördertechnik GmbH Representative Office

P.O. Box 35291  
Dubai, UAE  
Phone: +971 - 4 - 2823762  
e-mail: catalina@aumund.com

### THE NETHERLANDS

#### AUMUND Holding B.V.

Wilhelminapark 40  
5911 EE Venlo  
Phone: +31 - 77 - 320 01 11  
Fax: +31 - 77 - 320 07 28  
e-mail: info@aumund-holding.nl

### SWITZERLAND

#### AUMUND AG

Arther Str. 3  
6301 Zug  
Phone: +41 - 41 - 710 10 82  
Fax: +41 - 41 - 710 42 02  
e-mail: info@aumund.ch

### RUSSIA

#### AUMUND Representative Office

German-Russian House, Office 44  
ul. Malaja Pirogovskaja 5  
119435 Moscow / Russia  
Phone: +7 - 495 - 287 90 02  
Fax: +7 - 495 - 287 90 06  
e-mail: info@aumund.ru

### FRANCE

#### AUMUND France S.A.R.L.

43, rue de Trévisse - F 75009 Paris  
Phone: +33 - 1 - 42 46 72 72  
Fax: +33 - 1 - 42 46 72 74  
e-mail: aumund@aumund.fr

### BRAZIL

#### AUMUND Ltda.

Avenida Eng. Luis Carlos Berrini  
716 - 4.andar - conj. 41  
04571-000 - São Paulo / SP  
Phone: +55 - 11 - 3059 0160  
Fax: +55 - 11 - 3059 0161  
e-mail: aumund@aumund.com.br

### USA

#### AUMUND Corporation

1825 Barrett Lakes Boulevard  
Barrett Lakes Center II  
Suite 520  
Kennesaw, GA 30144  
Phone: +1 - 770 - 226 - 95 78  
Fax: +1 - 770 - 953 - 48 44  
e-mail: sales@aumundusa.com

### P.R. CHINA

#### AUMUND Machinery Trading (Beijing) Co. Ltd.

Rm. 7-8, 22-F, East Ocean Centre  
No. 24 Jianguomenwai Avenue  
Chaoyang District  
Beijing 100004  
Phone: +86 - 10 - 65 15 58 13 / 14  
Fax: +86 - 10 - 65 15 58 15  
e-mail: aumund@aumund.cn



SAMSON office building Ely, U.K.

AUMUND GROUP Headquarters in Rheinberg, Germany

# SAMSON

AUMUNDGROUP

Dedicated to providing the most comprehensive range of mobile solutions for bulk materials handling in Ports and Terminals, Mining, Environmental, Cement, Foodstuffs, Agriculture and Power.

Built around the unique concept of the Samson™ Material Feeder, SAMSON Materials Handling offer flexibility, reliability, quality, and industry leading performance from truck intake right through to mobile stacking and ship loading solution.

**SAMSON Materials Handling Ltd.**

**Gemini House, Cambridgeshire Business Park, 1 Bartholomew's Walk, Ely, Cambridgeshire CB7 4EA, England**

Tel.: +44-1353-665001 • Fax: +44-1353-666734 • e-mail: sales@samson-mh.com

[www.samson-mh.com](http://www.samson-mh.com)